

PELEMAN®

USER GUIDE

Flat Bed

Foil Printer



Version 2.21 August 2019
Flat Bed Foil Printer PC Tool version 1.2.x.0
Firmware version 2.47

TABLE OF CONTENTS

1	ABOUT THIS MANUAL.....	8
2	ABOUT FLAT BED FOIL PRINTER.....	9
2.1	Introduction.....	9
2.2	Specifications.....	10
2.2.1	Technical specifications.....	10
2.2.2	Software specifications.....	11
2.2.3	User related and other specifications.....	11
3	GETTING STARTED.....	12
3.1	Unboxing.....	12
3.2	What's Inside?.....	13
3.3	Setting Up The Flat Bed Foil Printer.....	14
4	FOIL HANDLING.....	18
4.1	About The Foil.....	18
4.2	Specifications Per Group.....	20
4.3	How To Insert The Foil.....	22
4.4	How To Remove The Foil.....	23
5	FLAT BED FOIL PRINTER PC TOOL.....	24
5.1	Introduction.....	24
5.2	What's New From Version 1.2.0.0.....	24
5.2.1	Key features.....	24
5.2.2	Printhead calibration.....	25
5.2.3	New foil groups.....	25
5.2.4	New sensors.....	25
5.3	Software Installation.....	26
5.4	Launch Application.....	27
5.5	Creating A New Design.....	28
5.5.1	Object Orientation.....	29
5.5.2	Printing on Spine.....	30
5.5.3	Parts of Printing Object.....	31
5.5.4	Print Areas.....	31
5.5.5	Print Margins.....	32
5.5.6	Design Toolbar.....	33
5.5.7	Saving Design.....	38
5.5.8	Inserting Text and Images.....	38
5.5.9	Selection, Movement and Alignment of Elements.....	41
5.5.10	Rotation of Elements.....	42
5.5.11	Foil Colour Layers.....	42

- 5.5.12 Rulers & Guidelines..... 44
- 5.5.13 Multiple jobs..... 45
- 5.5.14 Design Zooming..... 46
- 5.6 Open Design..... 46
- 5.7 Print Design..... 46
- 5.8 Tools..... 47
 - 5.8.1 Settings..... 47
 - 5.8.2 PELEMAN Products..... 50
 - 5.8.3 Check for Updates..... 51
 - 5.8.4 Request for Service..... 52
 - 5.8.5 Manage Templates..... 52
 - 5.8.6 Testing and Calibration..... 56
 - 5.8.7 Service Menu..... 60
 - 5.8.8 About the Foil Printer..... 60
 - 5.8.9 Help Button..... 61
- 5.9 Uninstall..... 62
 - 5.9.1 Uninstallation Using Start Menu..... 62
 - 5.9.2 Uninstallation Using Control Panel..... 62
 - 5.9.3 Uninstallation Using Installation Setup..... 63
- 6 MAINTENANCE..... 64**
 - 6.1 Basic maintenance..... 64
 - 6.1.1 Accessories..... 64
 - 6.2 Advanced maintenance..... 65
 - 6.2.1 Advanced maintenance by technician..... 65
- 7 TROUBLESHOOTING 67**
 - 7.1 Troubleshooting Bad Print Result..... 67
 - 7.2 Troubleshooting – Foil Is Not Spinning..... 67
 - 7.3 Troubleshooting – Calibration..... 68
 - 7.4 Troubleshooting – Errors..... 69
 - 7.4.1 No communication with the printer error/printer not connected..... 69
 - 7.4.2 Printer is damaged error..... 69
 - 7.4.3 Head error..... 70
 - 7.4.4 Dots damaged error..... 70
 - 7.4.5 Driver installation..... 70
- 8 SHIPPING AND TRANSPORTATION 71**
- 9 FREQUENTLY ASKED QUESTIONS (FAQs)..... 72**
- 10 APPENDICES..... 73**
 - 10.1 List of Keyboard Shortcuts..... 73
 - 10.2 Supported Template Dimensions..... 75

10.2.1 Type 1a and 1b.....	76
10.2.2 Type 2a.....	77
10.3 Built-in Printing Settings for Foils and Materials.....	78
10.4 Custom material grid.....	80
10.5 Default Template Specifications.....	82
10.5.1 Preset Margins.....	82
10.5.2 Factory Set.....	82
10.6 What's new.....	85
10.6.1 Version 1.0.0.63.....	85
10.6.2 Version 1.0.2.0.....	85
10.6.3 Version 1.1.0.0.....	85
10.6.4 Version 1.2.0.0.....	86
10.7 Parts and Accessories List.....	86

TABLE OF FIGURES

Figure 1: Flat Bed Foil Printer with Cover Placed to Print.....	8
Figure 2: Printed Design Examples.....	9
Figure 3: Cut Binding Strips.....	12
Figure 4: Unpackaging.....	13
Figure 5: Flat Bed Foil Printer Package Contents.....	14
Figure 6: Lock Tool and Support Removal.....	15
Figure 7: Flat Bed Foil Printer Connections.....	15
Figure 8: Use Supplied Underlay Materials for Different Applications.....	16
Figure 9: Different possibilities to use double paper clamp to hold the substrate.....	17
Figure 10: Connecting the Coils.....	22
Figure 11: Foil Inserted in fead of Flat Bed Foil Printer.....	23
Figure 12: Files Required for Installation.....	26
Figure 13: Available Options in All Programmes of Start Menu for Launching Application.....	27
Figure 14: Flat Bed Foil Printer PC Tool.....	27
Figure 15: New Design Startup Dialog Box for Selection of Template.....	28
Figure 16: Display for Selection of Appropriate Template & Associated object Orientation.....	28
Figure 17: Design Window Based on Selected Template and Object Placement.....	29
Figure 18: Vertical Spine Orientation (Left) and Horizontal Spine Orientation (Right).....	30
Figure 19: Vertical Spine Orientation (Left) and Horizontal Spine Orientation (Right).....	31
Figure 20: Margins (grey zone around the template).....	32
Figure 21: Design Toolbar.....	33
Figure 22: Design Toolbar Group 1 - Functions.....	33
Figure 23: Design Toolbar Group 2 - Tools.....	34
Figure 24: Design Toolbar Group 3 – Edit Functions.....	34
Figure 25: Design Toolbar Group 4 - Text Editing.....	35
Figure 26: Design Toolbar Group 5 - Element Alignment.....	36
Figure 27: Design Toolbar Group 6 - Rotation Degree.....	36
Figure 28: Design Toolbar Group 7 – XY Coordinates.....	37
Figure 29: Design Toolbar Group 8 – Make Database.....	37
Figure 30: Text box placed in a print area containing the text “My Photos”.....	38
Figure 31: Image Thresholding Menu.....	39
Figure 32: Image of palm tree placed inside print area.....	40
Figure 33: Layer Window.....	43
Figure 34: Rulers and Guidelines for Alignment.....	44
Figure 35: Zoom Slider & Buttons.....	46
Figure 36: Application Settings Tab in Available Tools.....	47
Figure 37: Units Setting for Rulers in Tools.....	47
Figure 38: Ruler Display Setting in Tools.....	48
Figure 39: Snap Setting in Tools.....	48
Figure 40: Setting in Tools for Automatic Search for Updates.....	48
Figure 41: Setting in Tools to Enable All Flat Bed Foil Printer Messages.....	48
Figure 42: Setting in Tools to Customise Printing Parameters.....	48
Figure 43: Settings for Printing Parameters.....	49
Figure 44: Setting in Tools for Transportation.....	50
Figure 45: Settings in Tools for Smart Temperature Control.....	50
Figure 46: Settings in Tools for Printhead Calibration.....	50
Figure 47: Tools to Check for Updates.....	51
Figure 48: Warning Message if Printer is Not Connected.....	51
Figure 49: Warning Message if Not Connected to Server.....	52
Figure 50: Screen for Managing Templates.....	53

Figure 51: Warning Message at Start of Creating New Template 53

Figure 52: Screen for Selecting Type of New Template 54

Figure 53: Screen for Inserting Dimensions of New Template 54

Figure 54: Screen for Inserting Dimensions of Window in New Template 55

Figure 55: Screen for Selecting Material, Softness and Name of New Template 55

Figure 56: Calibrate Printhead tab 56

Figure 57: Calibration Start Screen 57

Figure 58: Torque Sensor Test 58

Figure 59: Service Menu in Tools 60

Figure 60: About Flat Bed Foil Printer 60

Figure 61: Built-In Software Help 61

Figure 62: Uninstall Option in Start Menu 62

Figure 63: Uninstall Options in Control Panel 63

Figure 64: Uninstall Option in Software Installation Setup 63

Figure 65: Printer Statistics 64

Figure 66: SPUP0000134 - Head plate for Z-axis subassembly – GEN 2 65

Figure 67: Attach the locking tool and add cardboard supports 71

Figure 68: Dimensions of Double Side Cover with Window 76

Figure 69: Dimensions of Single Side Cover 77

LIST OF TABLES

Table 1: Compatible versions of software and firmware11

Table 2: Foil Colours 18

Table 3: Specifications and Indications of Foil Groups 20

Table 4: Keyboard Shortcuts.....73

Table 5: Settings for group A: Gold, Silver, Red and Blue Foils 78

Table 6: Settings for group B: Gold, Silver, Red and Blue Foils..... 78

Table 7: Settings for group C: Gold and Silver Foils for Offset Sheet 78

Table 8: Settings for group D: Black Foil 79

Table 9: Settings for group E White Foil..... 79

Table 10: Custom Material Grid80

Table 11: Factory template dimensions 82

1 ABOUT THIS MANUAL

This guide summarises the basic know-how required to *install and operate* the *Flat Bed Foil Printer* and its associated *Flat Bed Foil Printer PC Tool* utility applications of the latest versions starting from 1.2.0.0.

Visit our websites to download previous versions of the software like 1.0.0.63, with associated user guide: <https://flatbedfoilprinter.com/> or <https://webshop.peleman.com/en-be/machine/unifoilprinter>

This manual is divided into sections based on the different subject matters to provide users with all the necessary information in an easily accessible way.

- Section 2: Introduction of the Flat Bed Foil Printer
- Section 3: Information required to setup the printer and start working
- Section 4: Details of the foils
- Section 5: Basics of the software utility application
- Section 6: Maintenance
- Section 7: Troubleshooting
- Section 8: Shipping and transportation
- Section 9: Frequently asked questions (FAQs)
- Section 10: Appendices for additional information



Figure 1: Flat Bed Foil Printer with Cover Placed to Print

2 ABOUT FLAT BED FOIL PRINTER

2.1 Introduction

The Flat Bed Foil Printer allows you to personalise your books, notebooks, agendas, contracts and more. If you are about to present an offer, a contract or even yourself in a meeting, with the Flat Bed Foil Printer your work always stands out.

Flat Bed Foil Printer is an innovative digital printer that prints text and images with foil directly from a digital file on almost any flat and smooth material like paper, plastic as well as laminated cardboard materials. Designs are being created in the PC Tool application provided by Unibind Manufacturing Ltd.



Figure 2: Printed Design Examples

2.2 Specifications

2.2.1 Technical specifications

- Weight: 25 kg
- Size of machine: L: 615mm x W: 503mm x H: 295mm / in 'home' position L: 690mm
- Printer table dimensions: 600 mm x 310 mm
- Printable area: 450 mm x 300 mm [older versions: 410 mm x 280 mm]
- Active printhead area (strokes of): 57 mm
- Resolution: 300 x 300 dpi
- Speed: up to 2,5 cm/sec (1 inch/sec)
- Connection to computer with USB 2.0 (shielded)
- Electrical consumption: max. 72 Watt

2.2.2 Software specifications

- Operating systems for software version 1.0.0.63: Windows XP, Vista, Windows 7
- Operating systems for software version 1.0.2.0: Windows XP, Vista, Windows 7
- Operating systems for software version 1.1.x.0: Windows 7, Windows 8, Windows 10
 - Early versions of software can in some cases be installed on latest Windows versions with turned off driver signature enforcement.
 - Latest versions can in some cases be installed on early Windows versions - not fully supported.
- Operating systems for software version 1.2.x.0: Windows 10
 - off driver signature enforcement.
 - Latest versions can in some cases be installed on early Windows versions - not fully supported.
- Maximum template size: 480 mm x 480 mm
- Importable file formats: PDF, JPG, TIFF, PNG, GIF, BMP
- Software and firmware compatibility (it is highly recommended to not update software, firmware or O.S. when versions are not compatible).

Table 1: Compatible versions of software and firmware

Software	Firmware
1.0.0.57 or 1.0.0.63	2.11 or 2.14 or 2.17
1.0.2.0 or 1.1.0.0. or 1.1.1.0	2.17 or 2.28 or 2.32
1.2.0.0	2.41, 2.47 or up

2.2.3 User related and other specifications

- Spine supports included (for printing on spines)
- Total foil length: 100 m
- Different foil colours: red, blue, silver, gold, white, black (For more information and detailed foil features, please refer to the paragraph about the available foil options.)

3 GETTING STARTED

3.1 Unboxing



Tip: Scan the QR code to access the demonstrational video

Flat Bed Foil Printer is delivered in a wooden box. The box is very heavy, please pay attention and use a transporter or at least the help of one extra person.

After transportation to the selected location, open the box by cutting the binding strips as shown in figure 3.

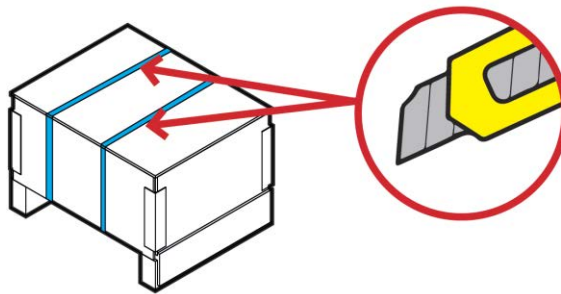

Figure 3: Cut Binding Strips

First, lift the lid, after that you can remove the cardboard sheets from between the buffers. Continue by lifting the wooden box up. Now you can remove protective buffers. Make sure you have space on the table where you wish to place the Flat Bed Foil Printer. Machine to be moved by two persons. Make sure that the Flat Bed Foil Printer is placed firmly on a desk. Remove the plastic bag.

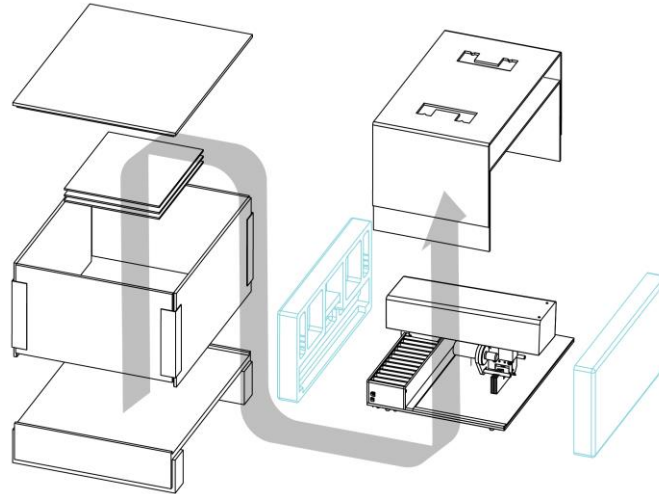

Figure 4: Unpackaging

3.2 What's Inside?

List of content (regular version):

- Flat Bed Foil Printer
- Powercable (1 of below)
 - EU = UFPRELEC018;
 - UK = UFPRELEC020;
 - US = UFPRELEC019
- Power supply UFPRELEC012
- USB cable UFPRELEC015
- Foil Gold UFPR0000002
- User guide SPUP0000103
- Quickguide SPUP0000104
- Lock removal instructions SPUP0000107
- Screwdriver SPUP0000111
- Spine support set (UFPRSUP0002 +3 +4 +5)
- Empty core UFPR0000005
- USB drive Flat Bed Foil Printer SPUP0000144
- Paper ring SPUP0000142
- Lock X-axis SPUP0000097
- 4x screw with cross head SPUP0000028
- Rubber/foam pad SPUP0000046
- Polycarbonate plate SPUP0000130
- Double paper clamp UFPR0000021 (NEW 2019)

Attention! Do not throw away accessories like the polycarbonate plate and foam pad.

Contact your representative to (re)order any items.



Figure 5: Flat Bed Foil Printer Package Contents

3.3 Setting Up The Flat Bed Foil Printer



*Tip: Scan the QR code to access
the demonstrational video*

Make sure you remove the 'locking tool' and supports first, before connecting the printer to power supply. Remove the lock tool completely with supplied screwdriver. Do not lose those items as they may be needed for transportation in the future. You can place the machine back in transport position via *Settings* in software. Never transport the machine without properly attaching locking tool.

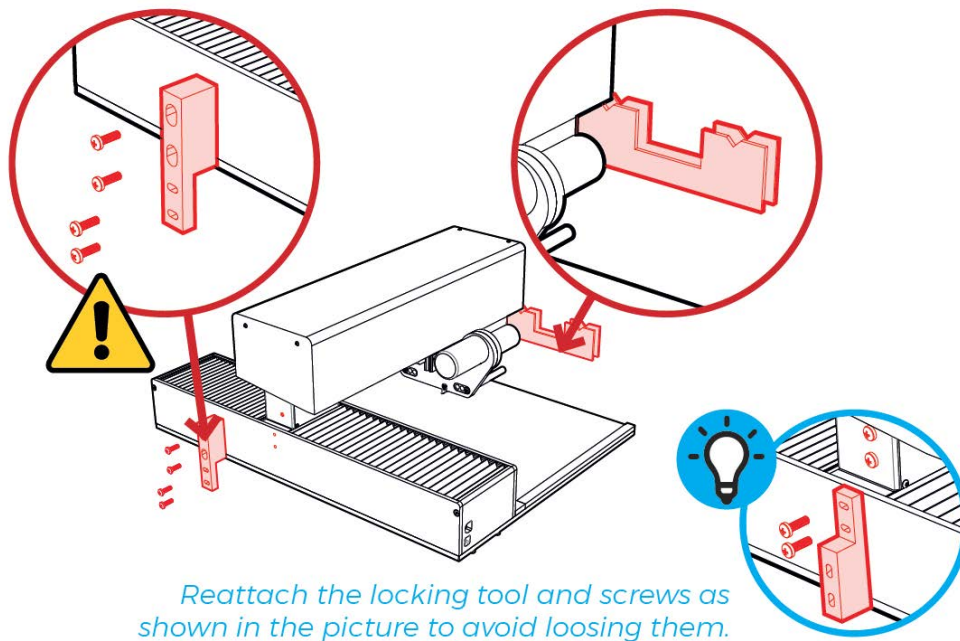

Figure 6: Lock Tool and Support Removal

Connect the Flat Bed Foil Printer to the computer with the provided USB cable. Make sure your computer has a grounded connection to the power supply.

Attention! Make sure the printing table is clear of objects and the lock tool has been removed.

Plug the power adapter into an electrical outlet to power the device. Printer will move to 'home position'.
Open the installed software (see section below) to check if the printer is connected to your computer.

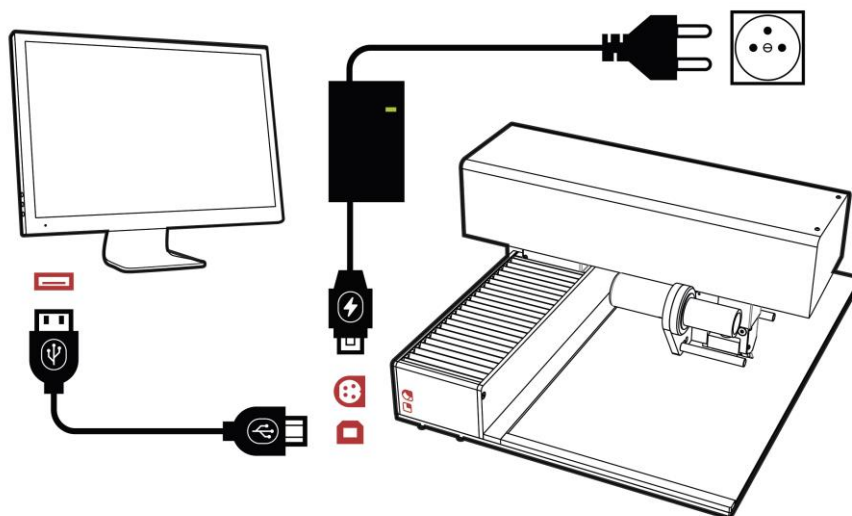

Figure 7: Flat Bed Foil Printer Connections

Depending on the medium that you will print on, use the acrylic plate or the foam pad. You don't need to remove one of the two completely. However, for some materials the result will be better when only one of two is being used on the aluminium printing table.

The underlay materials (acrylic sheet and foam pad) give the best support for the most known materials. Replace them for new on regular basis.

Use acrylic plate on top when printing on:

Smooth paper*, clear covers, flex covers and other bendable material. You also can use acrylic plate to glue materials like leather with double sided tape sheets.

*Use extra paper sheets as underlay when printing on paper.

Use foam pad in top when working with:

Hard covers, thick acrylic sheets and other hard, stiff materials.

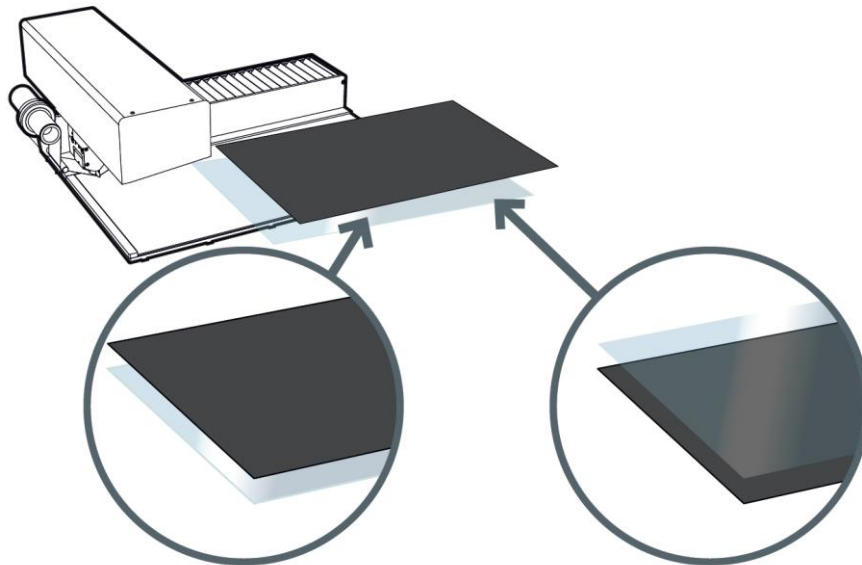

Figure 8: Use Supplied Underlay Materials for Different Applications

Use double paper clamp

Recently we started to add a paper clamp in the package (item UFPR0000021). You can use it to fasten your substrate. It can be used as a clamp to hold the substrate or as an end stop to avoid covers from moving during printing.

Attention: be careful with printing near the edge. Printhead can touch the clamp and get damaged.



Figure 9: Different possibilities to use double paper clamp to hold the substrate

4 FOIL HANDLING

4.1 About The Foil

The foil is the original thermal transfer ribbon (TTR) for Flat Bed Foil Printer. Foils shown below are used to print on covers and other materials.

To ensure that the Flat Bed Foil Printer works correctly, we recommend using only the original foil. The printhead can be damaged when using by non-original foil, especially foils for hot stamping.

Foils are categorised based on their features. Within the same group, the same settings can be used for the foils.

Table 2: Foil Colours

Picture	Item Code	New Name	Group
	UFPR0000001	Metal Silver	A
	UFPR0000002	Metal Gold	A
	UFPR0000003	Metal Blue	A
	UFPR0000004	Metal Red	A
	UFPR0000018	Metal Silver	B

Picture	Item Code	New Name	Group
	UFPR000001G	Metal Gold	B
	UFPR0000020	Metal Blue	B
	UFPR0000019	Metal Red	B
	UFPR0000012	Metal Silver	C
	UFPR0000013	Metal Gold	C
	UFPR0000006	Black	D
	UFPR0000014	White	E

Picture	Item Code	New Name	Group
	UFPR0000005	Core	/

4.2 Specifications Per Group

Below you will find specifications and indications for each group. You can use this as a reference to decide which foil can be ordered for your specific needs.

Please note that there is a large variety of materials as well as material qualities. Therefore, it is not possible to test all existing materials and material manufactures.

The list is being updated on a regular basis. Please feel free to contact us to share your results.

Table 3: Specifications and Indications of Foil Groups

Group	A	B	C	D	E
Range of application (only for smooth surfaces)					
Writing paper/ cardboard	**	***	**	**	N/A
Coated paper	****	***	***	***	N/A
Uncoated paper	*	***	**	N/A	N/A
PVC	*****	***	***	***	****
ABS	****	N/A	****	N/A	N/A
PE	***	N/A	***	N/A	***
Extruded acrylic	****	N/A	***	****	N/A
Smooth leather	*****	N/A	N/A	N/A	N/A
Smooth metal	N/A	N/A	N/A	N/A	N/A
Smooth wood	N/A	N/A	N/A	***	N/A

Foil specifications					
Group	A	B	C	D	E
Resin	✓		✓	✓	✓
Wax					
Wax-Resin		✓			N/A
Carrier Thickness	4.5µm	4.5µm	12 µm	4.5µm	+/-4.5µm
Total Thickness	+/- 6,8 µm	+/-7,6 µm	+/-13,5µm	+/-8.5µm	7 µm
Specifications					
food-contact safe	N/A	N/A	N/A	✓	✓
Scratch resistance	****	***	****	****	****
Gasoline resistance	N/A	N/A	N/A	/	N/A
Ethanol resistance	N/A	N/A	N/A	/	N/A
Storage temperature	+10 up to +35°C	+10 up to +35°C	+10 up to +35°C	N/A	+5 up to +35°C
Storage humidity	30-80%	30-80%	30-80%	N/A	30-85%
Recommendations	Keep away from direct sunlight	Keep away from direct sunlight	Keep away from direct sunlight	Keep away from direct sunlight	Keep away from direct sunlight Best within 12monts

*	Very poor
**	Poor
***	Good
****	Very good
*****	Excellent
N/A	No data available (yet)
V	Yes
/	None

4.3 How To Insert The Foil



Tip: Scan the QR code to access the demonstrational video

First, connect the new foil coil to an empty core. Make sure the metal rings are on the same side and connect the coils using the adhesive layer or use a piece of tape. Wind a few turns of foil to the empty core until the adhesive layer is covered. The foil must be straight and smooth.



Figure 10: Connecting the Coils

To position a foil, carefully place it on the foil holders as shown below. Make sure that the foil is mounted with the shiny coated side facing the printhead. Ensure the correct

installation. The foil must be firmly fixed under the metal bars and the centre of the printhead. For optimal use, the foil must be tight against the printhead. If needed, wind manually the left side counterclockwise,

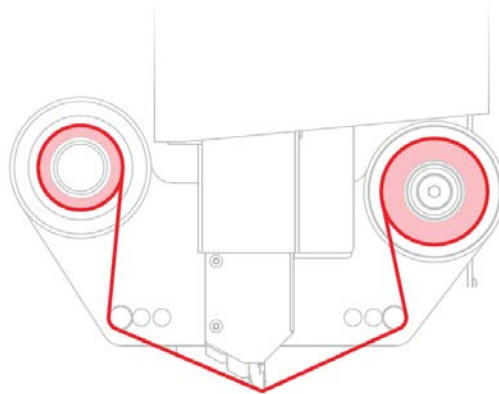

Figure 11: Foil Inserted in fead of Flat Bed Foil Printer

4.4 How To Remove The Foil

To change or remove the foil, gently pull both rolls at the same time. If you would like to remove one of the sides, cut the foil, replace empty core or replace foil with another colour.

Make sure the metal ring doesn't stay attached to the foil holder of the printer after removing the foil coil. If it happens, you can remove the metal ring from the printer with a strong magnet or a sharp knife. The ring can be glued back to the foil holder (same side) with super glue. Alternatively, you can ask for replacement from your representative.

5 FLAT BED FOIL PRINTER PC TOOL

5.1 Introduction

The Flat Bed Foil Printer software application, *Flat Bed Foil Printer PC Tool* is used as an interface between the user and the associated Flat Bed Foil Printer interface board. This chapter of the manual focusses on the basic know-how required to install and use the *Flat Bed Foil Printer PC Tool*. The relevant documents may be referred to for further information on the subject matter.

The *Flat Bed Foil Printer PC Tool* and the associated drivers need to be installed on the user's computer to successfully operate the device. The information and images provided in this manual have been specifically selected for Microsoft Windows 10. Thus, they may slightly differ for other versions / types of operating systems.

5.2 What's New From Version 1.2.0.0

5.2.1 Key features

To review all versions and the key improvements, please refer to the appendices of this manual.

Since latest machines comes with updates software, firmware and sensors there are a few remarkable features.

Key features:

- Printhead calibration*
- New foil groups & materials
- Improved coordinate system
- Image dimensions during import and in the template
- improved alignment functions
- PDF import options
- Multiple prints supporting .txt file formats
- Cursor improved
- Improved text boxes
- New and improved options in testing and calibration tab*
- Text rotation fixes
- Other small improvements and bug fixes*

*Some functions are only supported in latest firmware version 2.41 and up (provided with new machines).

5.2.2 Printhead calibration

The printhead consists of 672 tiny square electronic components, called resistors, aligned in a straight line. The electronic behaviour of each individual resistor in a specific printhead is identical and is identified by its value, further called R-value in this manual. Due to production tolerances the R-value between different printheads can vary with a maximum deviation of $\pm 10\%$ from the "ideal" value of 3000.

The different R-values between printheads results in different print results as the value directly influences the quantity of heat generated by the printhead.

The different print results can be eliminated by providing the R-value of a specific printhead in the software. The R-value can be found on the printhead.

Once the R-value is provided to the software AND the "printhead calibration" function is activated, the software will compensate the R-value deviation from the ideal value of 3000 and generate print results that are consistent between different printers.

The differences between printheads can be equalized by providing the R-value via software. The formula behind it will adjust your R-value to the printhead used for material testing.

This function together with smart temp control is used to get better print result for standard settings.

Usually, the correct value is set up in factory. You only need to switch it ON.

To calibrate: found via: Settings -> Testing and Calibration-> Calibrate Printhead

To switch ON: settings-> Printhead Calibration (ON)

Printhead changed? Adjust the value!

5.2.3 New foil groups

Peleman updated the foil identification system to provide better overview of existing foils and differences.

The foils are divided in groups according to their specifications. All foils within one group have same specifications and same settings can be used for printing. Colour is the main difference between the foils in one group.

Different groups can be used to print on different materials. See previous section about foil for more information.

5.2.4 New sensors

New machines from June 2019 will receive new position sensors. This will result in a different behaviour comparing to previous version.

Main advantage is correct print position after each print and power cycle.

5.3 Software Installation

Visit the website: <https://webshop.peleman.com/en-be/machine/unifoilprinter> or <https://flatbedfoilprinter.com/> to download the installation package or install the package from the supplied USB drive.

Make sure you use the software version compatible with your firmware. Please refer to the compatibility table in the software specification section.

In *Downloads* you will find software version(s) for download and installation. Download the .zip file and unpack the folder or use supplied USB drive to get the installation files.

The installation media includes 2 files (as shown in *figure 12*), which are required for the successful installation of the *Flat Bed Foil Printer PC Tool*. Please contact your local distributor or dealer if you encounter any difficulties in finding these files.

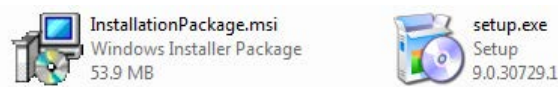

Figure 12: Files Required for Installation

To install the *Flat Bed Foil Printer PC Tool*, open the folder where these two files are located and start *setup.exe* to install the software application and the associated drivers. Follow the installation steps to perform the installation.

Please pay attention to:

- Licence agreement
- Installation folder
- Shortcuts
- Driver installation

5.4 Launch Application

To launch the application after installation, go to All Programs in the *Start Menu*, followed by *Flat Bed Foil Printer PC Tool* subfolder and finally select *Flat Bed Foil Printer PC Tool* as shown in *figure 13*.

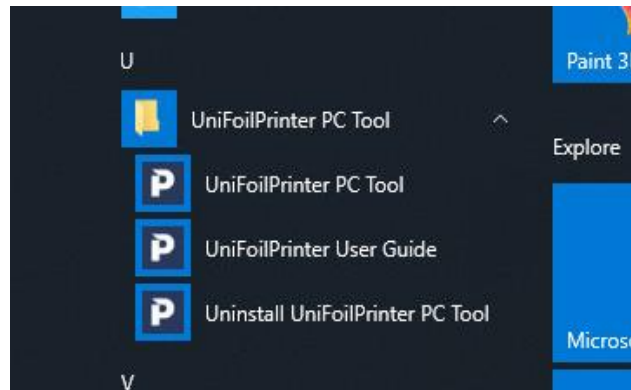

Figure 13: Available Options in All Programmes of Start Menu for Launching Application

A new application will be launched as shown in the *figure 14*.

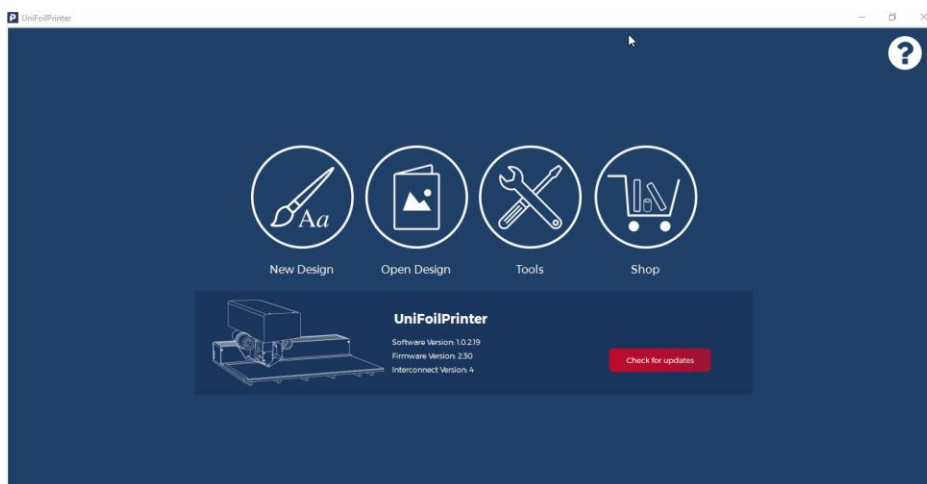

Figure 14: Flat Bed Foil Printer PC Tool

The software may also be launched through the shortcuts created on the user's desktop and/or quick launch folders. These shortcuts will only be available if the relevant option was selected during the installation process.

5.5 Creating A New Design

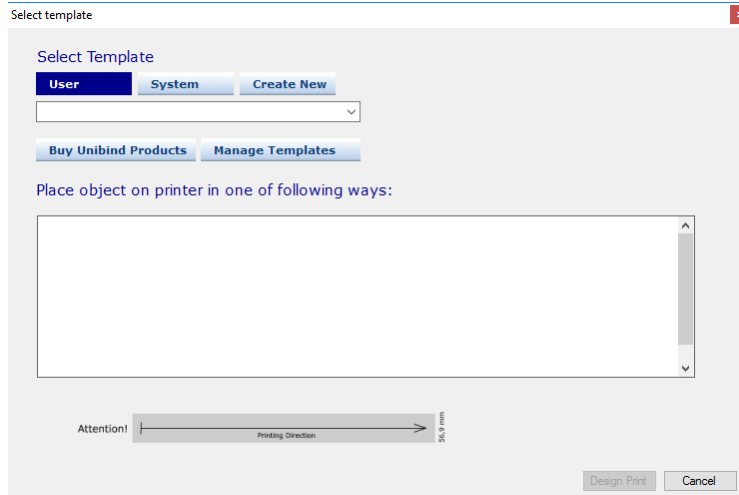

Figure 15: New Design Startup Dialog Box for Selection of Template

To create a new design, click on the *New Design* option from the listed possibilities. A new tab will open and a dialog box will appear as shown in figure 15.

Select the template that matches the object to be printed on from the list. You have the option to create a new template and select it afterwards from the 'User' tab or to select it from a list of preset templates. Template names refer to PELEMAN product names.

Make sure that the print object matches the selected template. Failure to do so can cause severe damage to the printer.

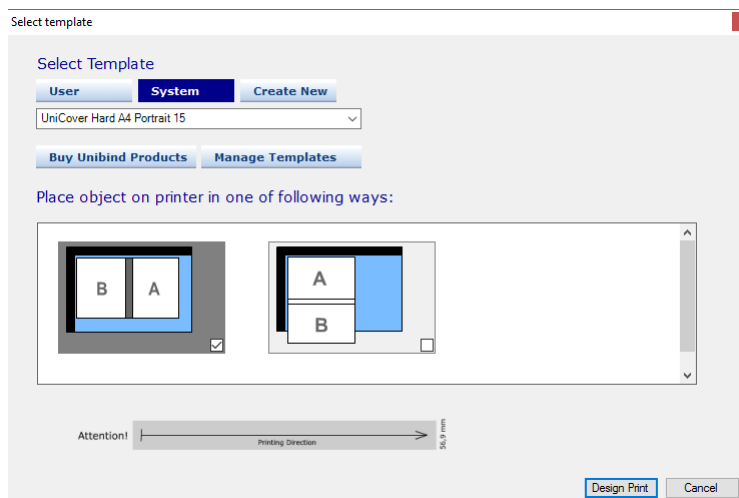

Figure 16: Display for Selection of Appropriate Template & Associated object Orientation

Once a template has been selected, possible orientations are displayed as shown in figure 16. Place the object on the printing table in one of the given ways, and selection of the same orientation on the screen as well. For more information about object orientation, please see section 5.5.1.

Click on *Design Print* button to open the new design based on the selected template and associated object orientation. A screen similar to *figure 17* will appear on the screen.

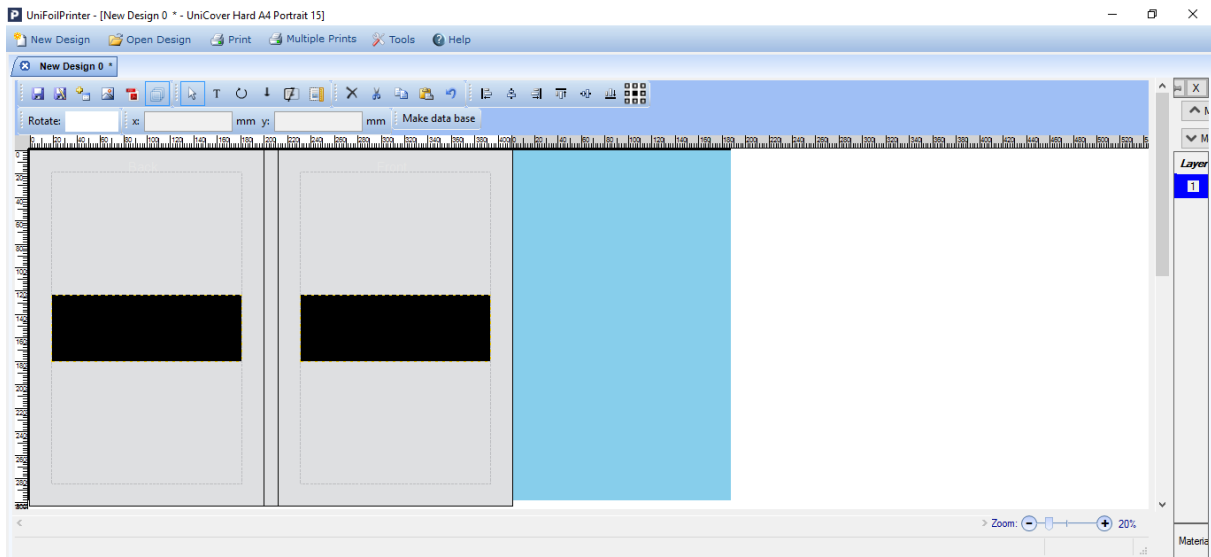

Figure 17: Design Window Based on Selected Template and Object Placement

With the help of available tools provided in the toolbar, create the desired text and graphics to be printed on the cover. Section 5.5.6 of this document may be referred to for more information on the toolbars.

5.5.1 Object Orientation

Important notes about **object orientation**:

- Due to the printhead width, each section of the design box is 57 mm high
- Printing is done from left to right in segments of 57 mm
- All design elements must fit within the margins of the print areas. You can enlarge print areas to over 57mm. In this case, when image or text does not fit within one area between the dashed lines, the element will be split and made with 2 or more strokes. In some printers, it can result in incomplete or imperfect areas.
- Orientation must be considered according to the elements used in these fields

Read more about print areas in section 5.5.4.

5.5.2 Printing on Spine

Printing on spine is only possible when the spine is horizontally oriented. Figure 18 illustrates the placement of print areas according to the orientation of the cover.

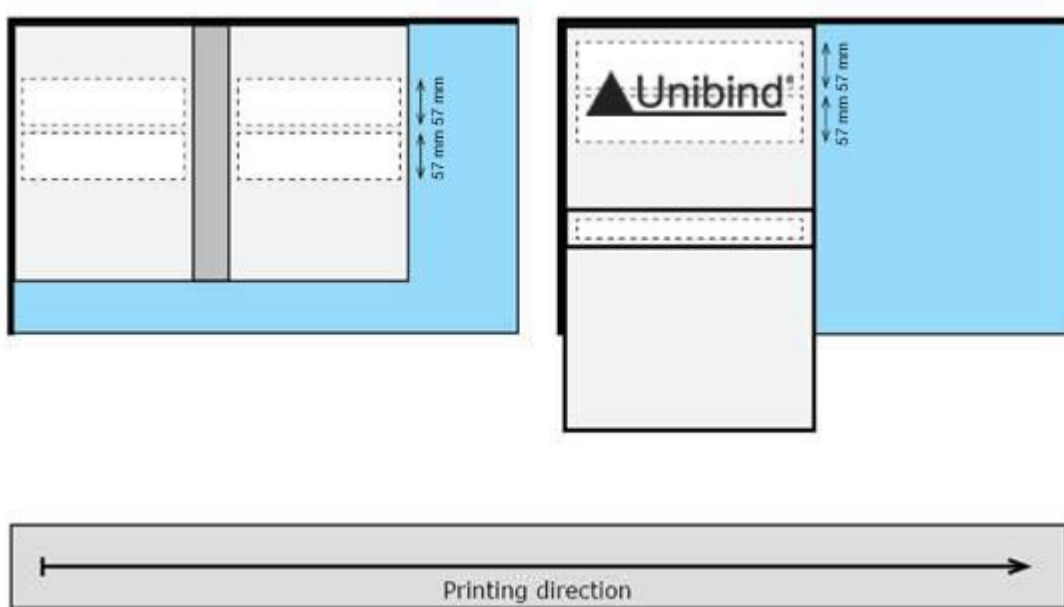

Figure 18: Vertical Spine Orientation (Left) and Horizontal Spine Orientation (Right)

Important notes about printing on spine:

- Select horizontal orientation of the spine for printing on spine.
- First, do a test print on the spine to double-check correct location.
- After a power cycle, the machine will auto calibrate on a bit different direction. Recheck the spine location first before printing on actual cover.
- When set up correctly, the centre of the head will go down in the centre of the spine.
- Elements inside a print area can be rotated at any degree but the direction of the print areas is set when object orientation is selected.
- Vertical spine orientation is most likely to be selected when designing the front and back of a cover, not the spine itself.
- The orientation of the design is saved during template selection. If the selected design for cover requires more than one orientation, two individual designs are needed on the same kind of template.

5.5.3 Parts of Printing Object

Cover with Spine

A cover with a spine should always lay flat on the printer's main table as seen in *figure 19*. The printer will print on the side facing upwards. A cover usually encompasses three printable parts, i.e. the front side, the back side and the spine.

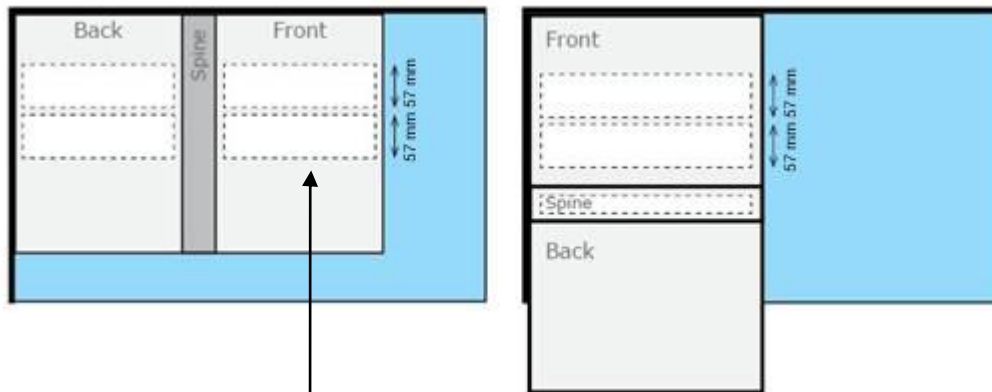

Figure 19: Vertical Spine Orientation (Left) and Horizontal Spine Orientation (Right)

Exceptions

- If the cover is placed on the table in a vertical spine orientation, the spine is unprintable.
- When a cover part is placed outside the printer table, the part is unprintable, e.g. the back side in horizontal spine orientation shown in *figure 19* is partially outside the printer table, so it is not printable in this orientation.

5.5.4 Print Areas

Print areas are non-printable **black** or **white windows** that are used to add printable elements in a design. By default, a print area is placed on every editable side of an object when a new design is opened. These areas are 57mm wide due to the size of the print head. Users can enlarge these areas. In that case, the printer will print the design in more than one stroke. Users may add or remove print areas according their design requirements. To add a new print area, click on the associated toolbar button for adding print area. The associated toolbar button is described in toolbar group 1 of section 5.5.6.

Print areas can also be moved up and down to a desired location by clicking on the given print area and dragging it (drag and hold) with the mouse as well as by using arrow keys on keyboard. Print areas can be aligned to the top, middle or the bottom of the object by clicking on the given element alignment buttons in the design toolbar described in toolbar group 5 in section 5.5.6.

Images can be imported to the print areas, and text can be typed inside these by using the associated design toolbars described in toolbar group 1 and 2, respectively, of section 5.5.6. Inserted elements can be moved around by using the same options as when altering print areas. **Only parts of the element placed inside the print area will be displayed and printed.**

***PRO Tip:** Repeat the same design by selecting the print area (with your design placed in it) and copy-pasting it on same spot (Ctrl+C – Ctrl+V). The machine can print the selected design repeatedly up to 10 times on the same spot.*

It is recommended to have thick foil layer on the same object or to make multiple prints on different objects.

5.5.5 Print Margins

In order to ensure the quality of the print, a certain size of margins always remains unprintable. Thus, it is not possible to print edge to edge on any objects. These margins are defined by the *Flat Bed Foil Printer PC Tool* and are unchangeable.

Standard margins are 19mm and we advise these margins to prevent errors/incorrect head placement. Narrow margins are 8mm and available during custom template creation.

Section 10.5.1 may be referred to see the values of these margins.

Flat Bed Foil Printer PC Tool will automatically reject elements to be placed on these print margins.

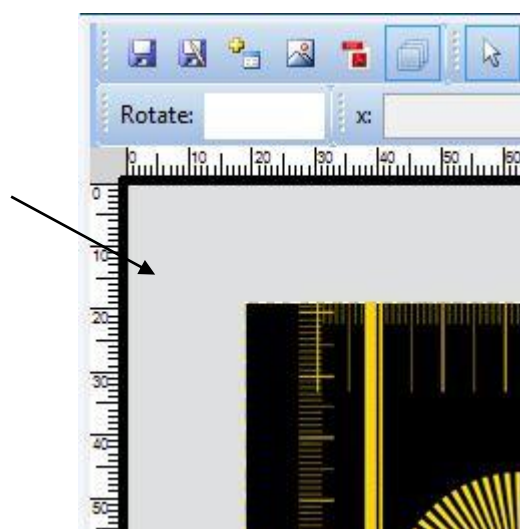

Figure 20: Margins (grey zone around the template)

5.5.6 Design Toolbar

The design toolbar, shown in *figure 21*, can be seen at the top of the design tab sub-window. It offers various functionalities for different purposes. The toolbar groups can be reorganised and relocated into different lines to suit the user's needs.

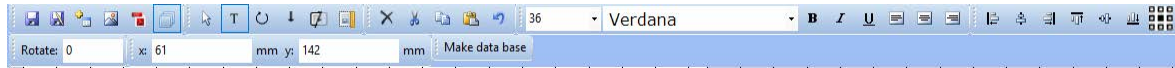

Figure 21: Design Toolbar

The following is a brief description of the toolbar options:

Group 1: Functions

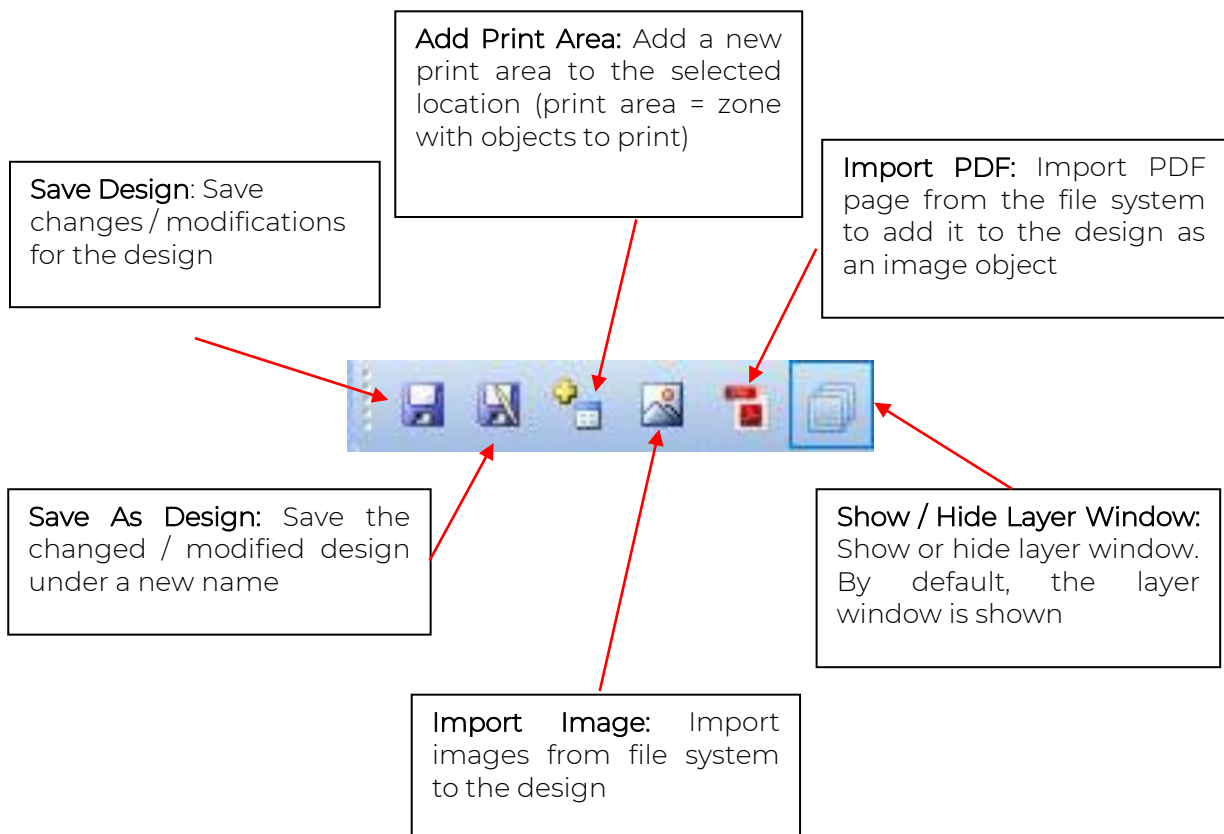
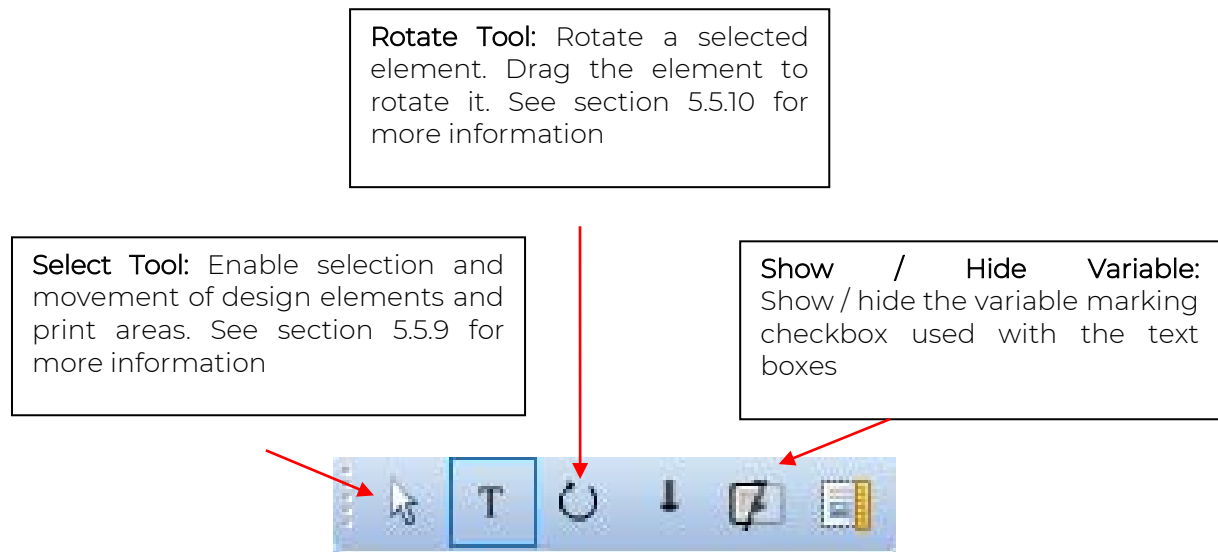

Figure 22: Design Toolbar Group 1 - Functions



Group 2: Tools

Figure 23: Design Toolbar Group 2 - Tools

Group 3: Edit Functions

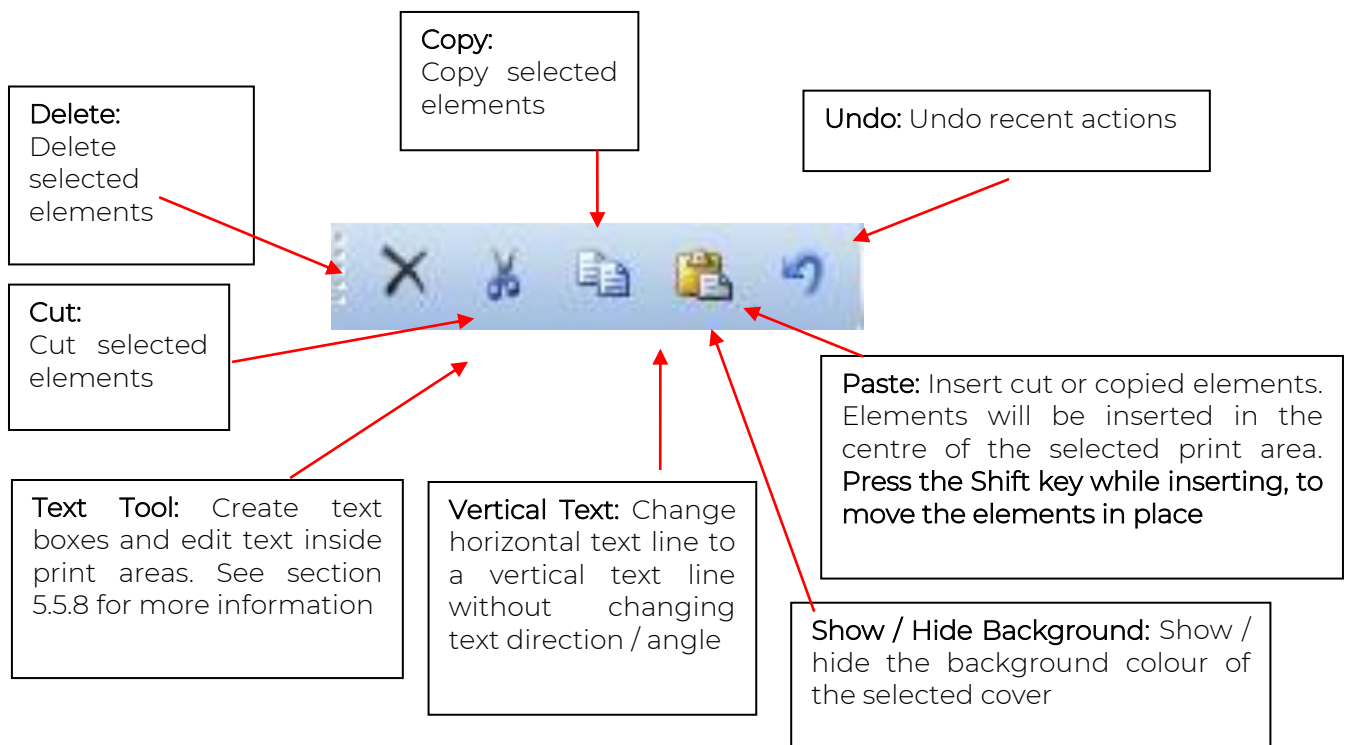

Figure 24: Design Toolbar Group 3 – Edit Functions

Group 4: Text Editing

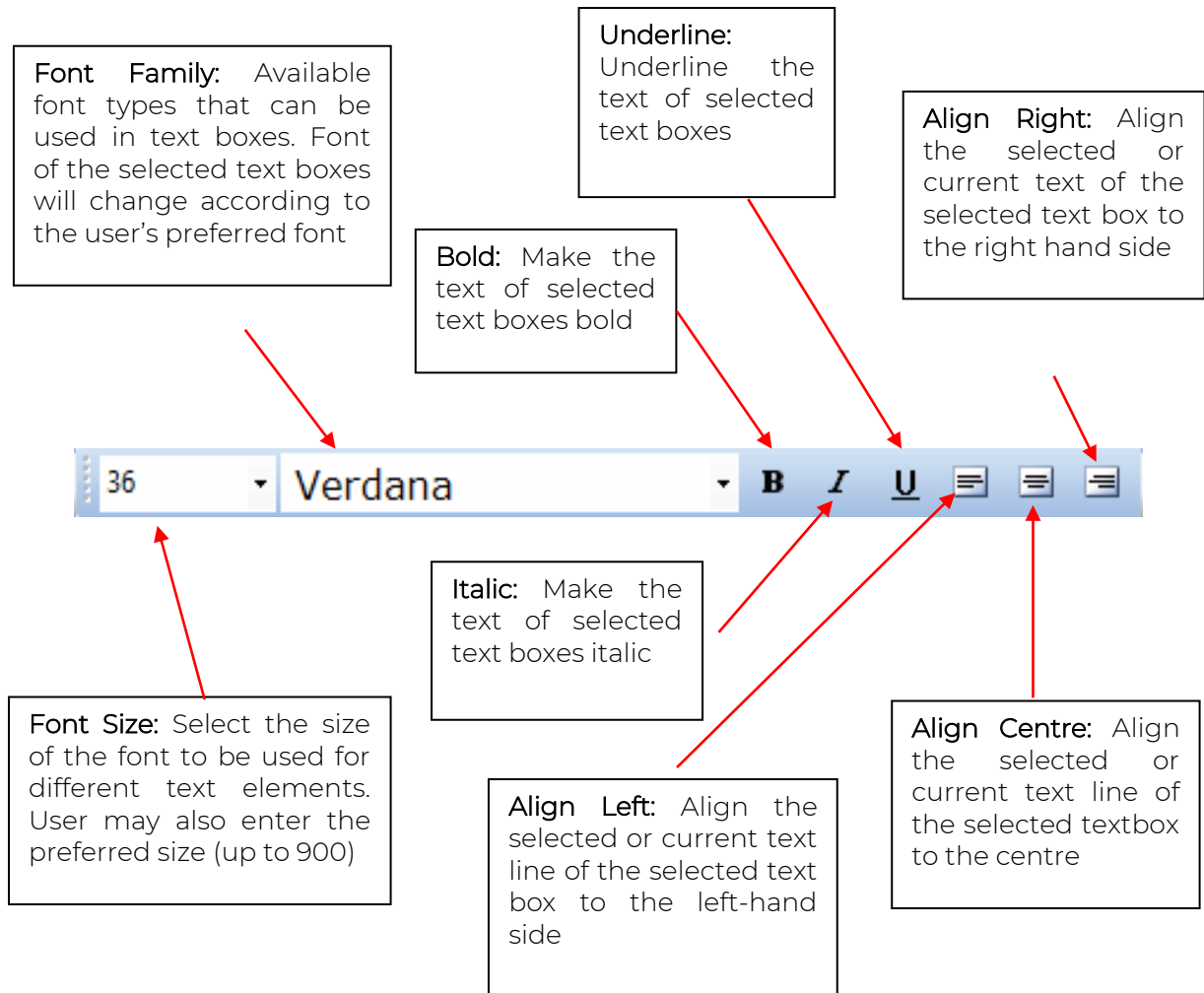
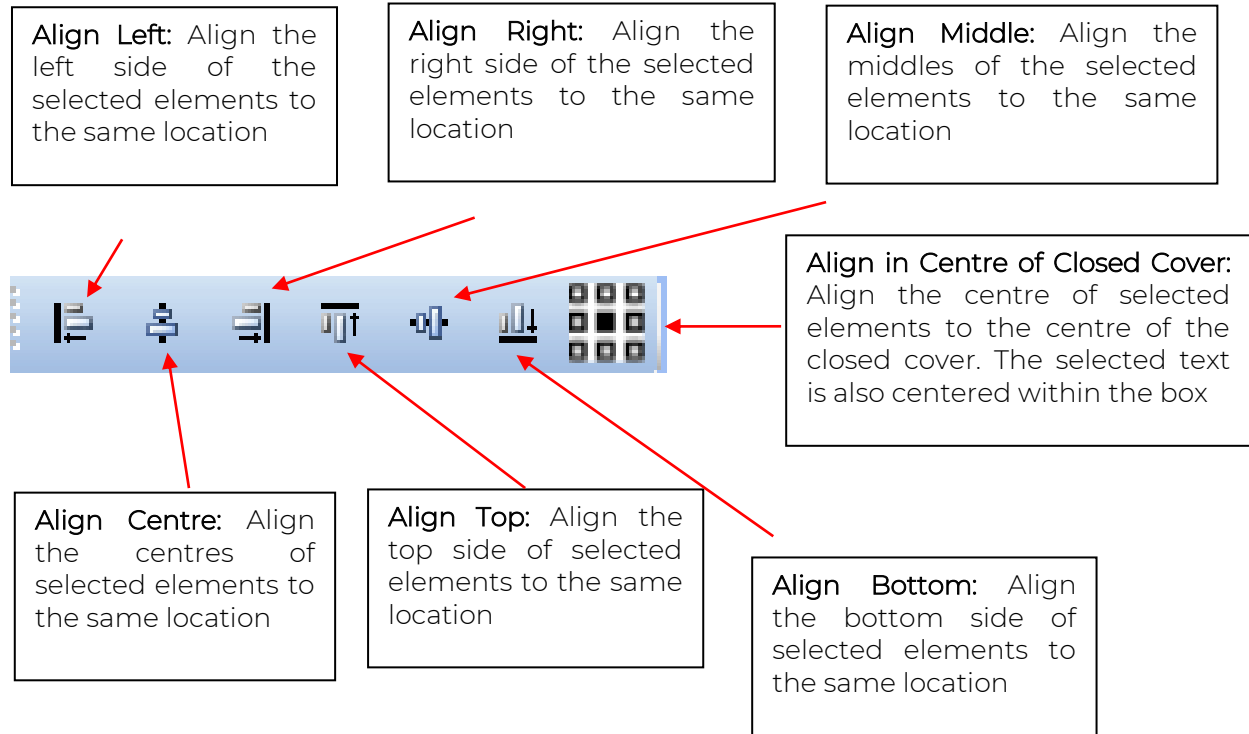

Figure 25: Design Toolbar Group 4 - Text Editing

Text Editing toolbar will **only be shown** when a text box is selected and text in it is being **inserted or edited**. The given font options will apply to the **selected** text in the text box or to the current cursor position if no text is selected. Similarly, the alignment options will apply to the selected lines within a text box or to the current line, if no text is selected.

Group 5: Element Alignment



The image shows a toolbar with eight alignment icons. Red arrows point from each icon to a corresponding text box explaining its function:

- Align Left:** Align the left side of the selected elements to the same location
- Align Right:** Align the right side of the selected elements to the same location
- Align Middle:** Align the middles of the selected elements to the same location
- Align in Centre of Closed Cover:** Align the centre of selected elements to the centre of the closed cover. The selected text is also centered within the box
- Align Centre:** Align the centres of selected elements to the same location
- Align Top:** Align the top side of selected elements to the same location
- Align Bottom:** Align the bottom side of selected elements to the same location

Figure 26: Design Toolbar Group 5 - Element Alignment

If a single element is selected, the alignment buttons will align to the edges and centre of the print area.

Group 6: Rotation Degree

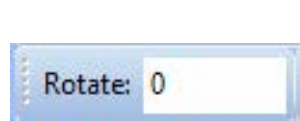

Rotate: Rotate the selected elements to the required angle. By default, the angle of rotation for an element is 0 degree

Figure 27: Design Toolbar Group 6 - Rotation Degree

Group 7: XY Coordinates

Units of XY Coordinates: May be either mm or inch based on the selected setting in 'Tools'

Figure 28: Design Toolbar Group 7 – XY Coordinates

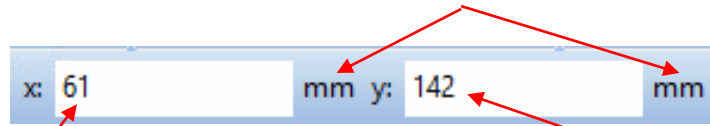

X Coordinate: Indicates the X location of the selected element or print area

Y Coordinate: Indicates the Y location of the selected element or print area

Group 8: Make Database

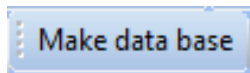

Make Database: Creates a TXT or CSV database in a new tab. This database contains values for the selected variable text boxes in the associated design.

To make the text variable, right click on the text box and select the option.

Figure 29: Design Toolbar Group 8 – Make Database

5.5.7 Saving Design

To save a new design, press the *Save* button in the design toolbar. A dialog box will appear to enter the name of a file. The Flat Bed Foil Printer design files will have the file extension *.upf*. The default path for saving any design is a subfolder named *Flat Bed Foil Printer Designs* located in the *My Documents* folder. It is recommended to save all Flat Bed Foil Printer designs in either the default folder or within one of its subfolders.

To save the changes done to an existing design, press the *Save* button in the design toolbar, and the changes saved to the existing design will be saved under the same file name.

To save an existing design under a different file name, either click on the *Save As* button or hold down *Ctrl + Shift* keys of the keyboard and then select *Save*. A dialog box will open to enable entry of another file name.

Toolbar group 1 in section 5.5.6 may be referred to for more information about *Save* and *Save As* toolbar buttons.

5.5.8 Inserting Text and Images

Text and images can be inserted in the displayed print areas. They will appear inside the dotted-line boxes with handles in every corner. The handles are displayed as hollow squares. Text boxes and image boxes are in general referred to as design elements in this document. Figure 30 and *figure 32* are examples of how images and text boxes appear.

To insert text, the given *Text* tool button in the design toolbar is used. When the *Text* tool is selected, click on a desired spot inside a print area. When the text box appears, enter the text while the *Text* tool is selected. Place the cursor in the required location to edit the text.



Figure 30: Text box placed in a print area containing the text "My Photos".

To resize the text box, click on the *Select* tool in the design toolbar. When mouse is over the handles, the select tool turns into a *Resize* tool. Click on the corner and drag the mouse while holding down the mouse button.

When the *Text Auto Resize* option is on, the text box will be automatically resized according to the text size. Section 5.8.1 may be referred to for further information.

Tip: Double-click on a text box with *Select* tool and the tool will change into Text tool, enabling text editing.

Single clicking with the mouse at any text position will place the cursor at click location and make the text editable. On the other hand, double-clicking with the mouse button will select the entire text within the text box. Associated keyboard shortcuts may be used for cursor movement and text selection. Section 10.1 of this guide may be referred to for available keyboard shortcuts for different functionalities.

To insert images, they must be first imported using the *Import Image* button in the design toolbar. Select the preferred print area for the image before proceeding with the *Import Image* option. Upon pressing the *Import Image* button, a dialog box will appear enabling search for image files. Please note that only the following image file types are supported by the *Flat Bed Foil Printer PC Tool*: BMP, GIF, JPG, TIFF and PNG. Select the desired image file and click the *Open* button of the file selection dialog box.

Tip: PDF pages may also be imported as images using *Import PDF* toolbar button discussed in toolbar group 1 of section 5.5.6.

Whether the selected image is grayscale or colourful, an image threshold menu will appear, like the one shown in *figure 31*, with the following options.

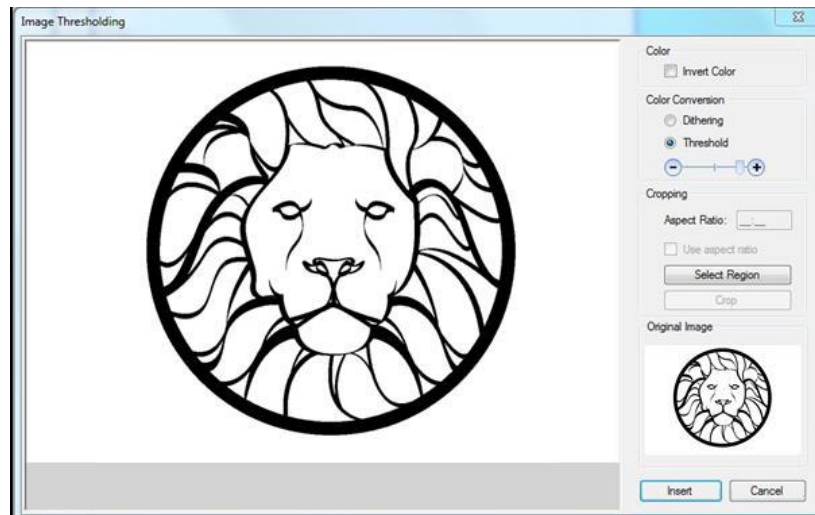

Figure 31: Image Thresholding Menu

- **Invert Colour:** The negative of the image (black=to be printed)
- **Colour Conversion:** Offers a choice between Dithering and Threshold
- **Cropping:** Makes it possible to use selected part of the image.



When **Dithering** is selected, the image is formed by a cluster of closely placed dots, creating an illusion of contrast



When **Threshold** is selected, the image is black and white, without any contrast. The threshold can be adjusted using the plus and minus buttons. Once the threshold level is satisfying, press the *Insert* button

PRO Tip: In some colour images, you can split the colours with the threshold function. By importing the parts in different layers, you can make multi-coloured foil images in minutes.

The image will appear in the selected print area as shown in *figure 32*. Use the arrow keys on the keyboard or the mouse to drag and move the image to the desired location.



Figure 32: Image of palm tree placed inside print area

Tip: Drag down the dotted line to open the print area for images larger than 57 mm.

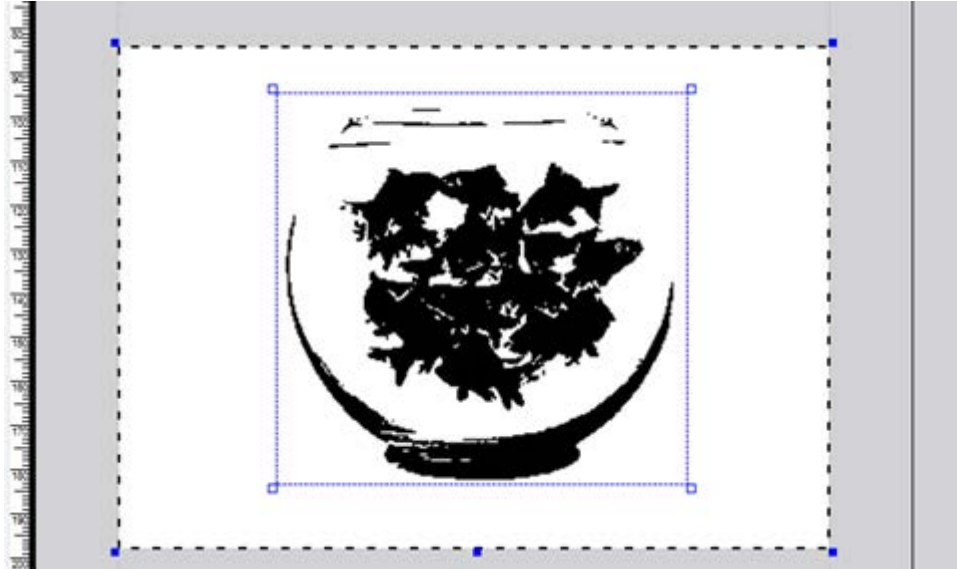

5.5.9 Selection, Movement and Alignment of Elements

An element may be **selected** by clicking on the *Select* tool shown as an arrow in *figure 23* and then clicking on the element. To select multiple elements, hold down the *Shift* key on the keyboard and then click on the elements one by one.

An element may be **moved** by selecting it with the mouse and then dragging it to the desired location, while holding down the mouse button. A borderline helps to avoid the element to be placed completely outside the print areas. This limit is 50% of the element to be placed outside the print area. When moving an element outside the print area, only the part inside the print area remains visible and will be printed. Elements can also be moved using arrow keys on the keyboard.

An element may be **aligned** to the top, middle or bottom side vertically and to the left, centre or right side horizontally within its design area by selecting the element and then clicking on the appropriate element alignment button shown in *figure 26*. Similarly, an element may be dragged to a specific location by clicking on the element with the mouse after selection, and then dragging it to the required position within its design area while holding down the mouse button. Section 5.5.12 of this document may be referred to for more information about aligning elements with guidelines.

When multiple elements are selected and aligned using the toolbar shown in *figure 26*, all elements will get aligned according to the first selected element. For example, if multiple elements need to be aligned to the left, then all elements will move except the first selected element, in such a way that the left side of all elements will be aligned to the left side of the first selected element.

Tip: For optimal results, elements must be placed between the dotted lines. Elements touching these dotted lines will lead to broken designs and imperfect results.

5.5.10 Rotation of Elements

A user may rotate any element either manually through the *Rotate* button shown in *figure 23*, or automatically, to the desired angle by entering the value of required degrees of rotation for the element in the rotate field shown in *figure 27*.

To rotate an element manually, the user must select the element and the *Rotate* button from the toolbar shown in *figure 23*. After that, drag the mouse while holding down the mouse button until the element is rotated to the required degree.

The rotate field in toolbar shown in *figure 27* will also show the value of the rotation angle for the selected element. A user may also rotate the element to the desired angle by selecting the element and then entering the value of degrees in the rotation field.

Tip: While the Shift key on the keyboard is pressed, the Rotate tool temporarily functions as the Select tool

Please note that when selecting multiple elements, each element will rotate about its own centre. Section 5.5.9 of this document may be referred to for more information.

5.5.11 Foil Colour Layers

The Flat Bed Foil Printer supports all foil colours discussed in section 4.1. Each colour is handled as a separate layer. These layers are shown in a separate layer sub-window that is visible on the right side of the design tab. If the layer window is not visible, click on the show / hide layer window toolbar button. By default, the layer window automatically resizes in width to hide most of the contents. By placing the mouse over this layer window, the window can be expanded. Users may use the pin button at the top of this layer window to enable / disable this auto hide feature of the layer window.

By default, the selected foil colour is *A-Metallic Gold*. If another foil colour is to be used for printing, it can be selected in the layer window. Changing the foil colour of the selected layer changes the print colour for each element associated with that layer. The foil colour per group (A, B, C, D or E) is only a preview and will not result on settings for the selected material. Please note that not all groups contain same colours.

The cover **material associated with the selected layer is displayed at the bottom of the layer window**. By default, '*Black*' material is selected. Users may select the material from the given list associated with each selected layer. The material will result on the print settings. Change settings for that specific material in the selected foil group if print quality is not as expected.

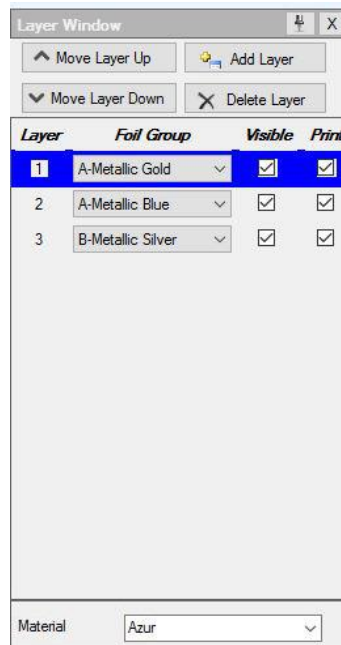

Figure 33: Layer Window

Multiple colours may be used on one object. Add separate layers in layer window for each colour. Elements inserted in one foil colour layer stay visible when another foil colour layer is selected. Only foil colour layers that contain elements will be printed. The *Flat Bed Foil Printer PC Tool* software will guide the user through the process of changing foils.

Users may activate or deactivate the visibility and print function for each layer by choosing the appropriate checkboxes for each layer. New layers can be added; existing layers can be deleted as well as rearranged within the layer window by using the associated buttons available at the top of the layer window.

Tip: The material will define the ideal settings. To change settings due to unsatisfactory print results, either click 'Adjust Print Settings' in the top menu or go to 'Tools' -> 'Customize' and edit settings of existing material or add a new one with other settings. Users will need to select the corresponding material in material window before printing on it.

5.5.12 Rulers & Guidelines

The rulers are usually used to align elements in the design window. Two types of rulers can be seen during the design process, i.e. horizontal ruler and vertical ruler. The horizontal ruler is displayed at the top of the design and is used to align elements horizontally. On the other hand, a vertical ruler is displayed on the left side of the design and is used to align elements vertically. The white area of the ruler corresponds to the allowable area where elements may be placed, while the inactive grey areas indicate those parts of the object where a user cannot insert any design element. The inactive grey area is either caused by print margins or because a part of the object is not supported by the printer table. Section 5.5.3 and section 5.5.5 may be referred to for more information.

By default, the rulers are always displayed during the design stage. Users may show / hide rulers using the settings tab in the available tools. The default unit for displaying measurements on the rulers is millimetre (mm). Users may change the units to display measurements on the rulers from the Settings tab in the available tools. Section 5.8.1 of this document may be referred to for more information on how to show / hide rulers and how to change units.

Guidelines for alignment are non-printable light blue colour lines, as shown in *figure 34*, that may be used to align elements, corresponding to some specific measurements on the ruler. To place a horizontal guideline, the user will have to click on the top ruler and drag the pointer line on the design area to the required corresponding position of the vertical ruler while holding down the mouse button. Similarly, to place a vertical line, the user will have to click on the left ruler, and drag the pointer line on the design area to the required corresponding position of the top ruler, while holding down the mouse button.

Users may add any number of such guidelines to a design. Similarly, to move any guideline to another location, a user may click and drag it to elsewhere, by holding down the mouse button during dragging.

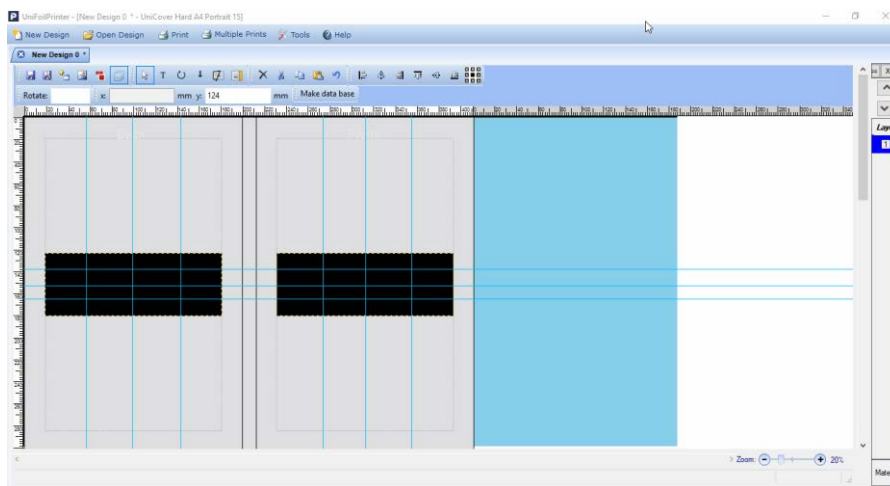
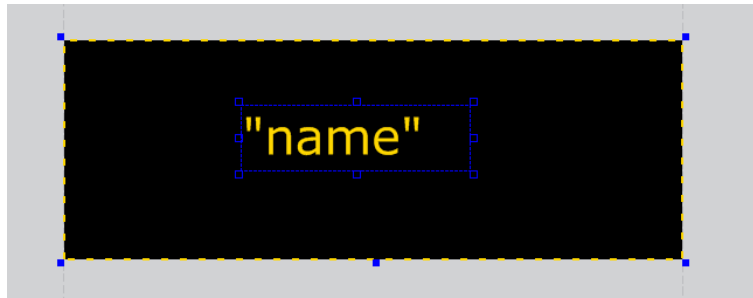

Figure 34: Rulers and Guidelines for Alignment

5.5.13 Multiple jobs

When printing multiple books with different text, it is suggested to use the multiple jobs + variable functions.

- **Step 1:** Create a text box and enter your text (example "name"). This text will be changed by your custom text in data file later. Please make sure the text box is big enough to prevent incomplete or spilt text. We advise to make the text box from side to side and align text in centre, if needed.



- **Step 2:** Make the text box variable by selecting *Variable Text* tool from the toolbar or right clicking with the mouse on the text box, then selecting the variable checkbox appearing above the textbox and marking it for multiple values.
- **Step 3:** Save the design and then click on *Make Database* button in the toolbar to create the TXT or CSV database file. The database will appear in a new tab next to design window tab.
- **Step 4:** You can edit the database file in the PC Tool software (go to step 5) or another programme like Notepad or Excel. The database file will have the same name as the design but with a different extension (can be found in the same folder where your designs are saved). You can now edit the separate file externally and save it under the same name and extension.
- **Step 5:** Use multiple lines. Use a new line for each word. Or, if values are entered externally and saved in another program (see step 4), you may refresh the database to make sure everything is set correctly.
Example:
Name 1
Name 2
Name 3
....
- **Step 6:** Go back to your design. Click on *Multiple Prints* at the top of application. Select *Print variable design* with option all variables or select specific variables like described in the window. Finally, click on *Print* button in the dialog box to start printing.

MultiPrint Form

Print static design Number of copies:

Print variable design All variables

Variable

Type the number of variable rows,
separated by commas, counting
from the start of the list.
For example 1,3, 5-12

- **Step 7:** The print process will start. Follow the instructions on the screen and replace the cover after each print.

5.5.14 Design Zooming

Users may zoom IN or zoom OUT within the design window using either the slider or the associated plus and minus buttons provided at the bottom right side of the application as shown in *figure 35*. Alternatively, the Shift + mouse scroll can be used to zoom IN or OUT.



Figure 35: Zoom Slider & Buttons

5.6 Open Design

To reopen a design, click on the *Open* option. The menu items are provided at the top of the application window. A dialog box will appear to select the design file. Flat Bed Foil Printer design files will have the file extension *.upf*.

5.7 Print Design

To print any saved design, the design must be opened in the application. To print the design, click on the *Print* button in the menu at the top of the application window. Similarly, a new design can also be printed right after the completed process by clicking on the *Print* button without closing the design.

Follow the instructions carefully to achieve perfect printing results.

To print multiple copies of the same design, use the *Multiple Prints* button instead of using *Print* button. Similarly, to have different prints for the same design by replacing multiple values for the text in text boxes, use variable design option of multiple prints. Section 5.5.13 of this manual may be referred to for more information.

5.8 Tools

Other multiple tools are available in *Flat Bed Foil Printer PC Tool*. These additional tools are related to different settings, updates, service request, calibrating the Flat Bed Foil Printer, creating and managing templates and more. A brief overview of these additional tools is provided here for reference.

5.8.1 Settings

The settings tab in tools shown in *figure 36* details the customisation of the application.

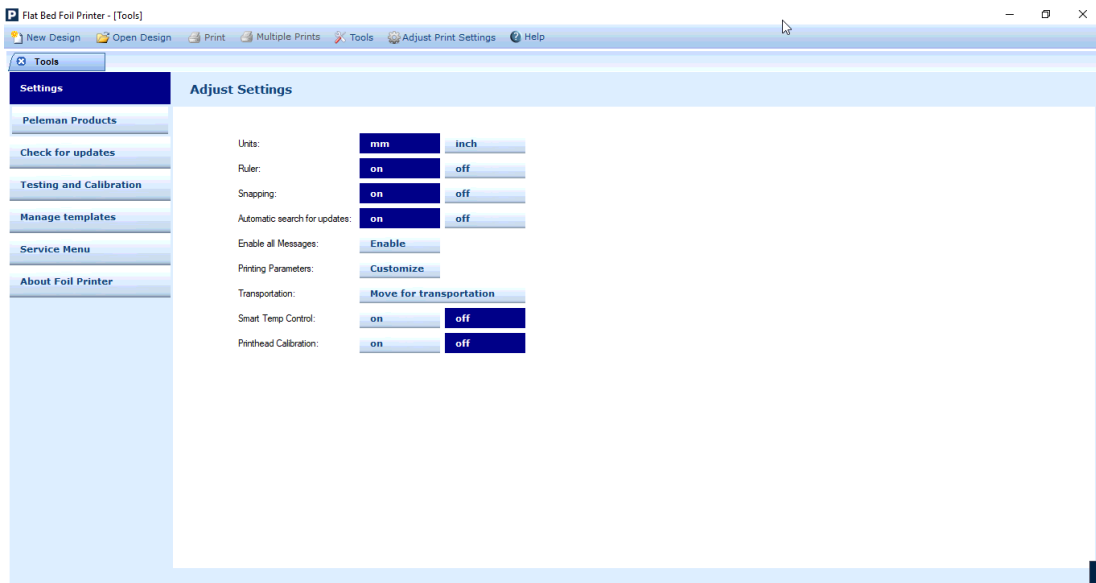

Figure 36: Application Settings Tab in Available Tools

- **Changing Units**

This setting relates to the units used on the ruler when it is displayed during the creation / editing of designs. Its default value is millimetre (mm).

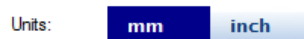

Figure 37: Units Setting for Rulers in Tools

- **Switching Display of Ruler On / Off**

Enabling or disabling the ruler. Users may set it to *on* state if the ruler is required to be displayed; otherwise it is set to *off* state. Its default value is *on*.

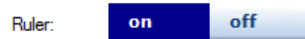

Figure 38: Ruler Display Setting in Tools

- **Snapping On / Off**

Enabling or disabling the functionality of snapping of objects against the construction lines. Its default value is *on*.

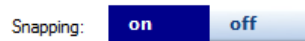

Figure 39: Snap Setting in Tools

- **Automatic Search for Updates**

Enabling or disabling automatic search for updates. Its default value is *on*.

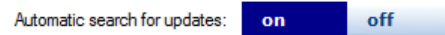

Figure 40: Setting in Tools for Automatic Search for Updates

- **Enable All Messages**

Enable all Flat Bed Foil Printer messages. Messages can be disabled by choosing the “Don't display this message again” option. By default, all messages are enabled.

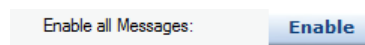

Figure 41: Setting in Tools to Enable All Flat Bed Foil Printer Messages

- **Printing Parameters**

Customisation of parameters associated with printing. It is one of the most essential functions in the software as it allows users to adjust settings for the different foil materials.



Figure 42: Setting in Tools to Customise Printing Parameters

The dialog box, like the one shown in *figure 43*, is displayed when clicking the *Customize* button. This dialog box contains settings for different printing parameters for each type of

supported foil. The parameters include torque, burn time and printing speed for both sides of the cover as well as for spine.

- Torque value is between 0 and 240. Increasing the torque value will result in more pressure on the printing material. If the torque is too high, the printing material can be damaged leaving indentations. If it is too low, it can cause an incomplete print.
- Burn time value must be from 300 to 2500. The foil needs heat to stick to a material. The higher the burn time the more heat is being transferred to the foil. If the heat is too high, the foil will break and loose shine. If it is too low, it will result in an incomplete print.

This setting is to be adjusted when the torque setting is maximal for your material without leaving indentations.

- Printing speed must be from 5 to 25. The value of printing speed is converted to actual speed in such a way that for example a value of 25 will mean a speed of 25 mm / second.

It is recommended to keep the speed around 10 and adjust other settings first. You can adjust printing speed when burn time is maximal but there is still not enough 'heat' to allow the foil transfer onto the material. Increasing print speed will also increase burn time.

- Motor speed adjusts the speed for winding up the foil. The higher the speed the higher the tension.

This setting needs to be adjusted when the foil starts wrinkling under the printhead for custom materials. Usually a combination of 10 for print speed and 30 for motor speed is recommended.

The recommended default values for these settings depend on the type of cover material. Section 10.3 may be referred to for further details in this regard.

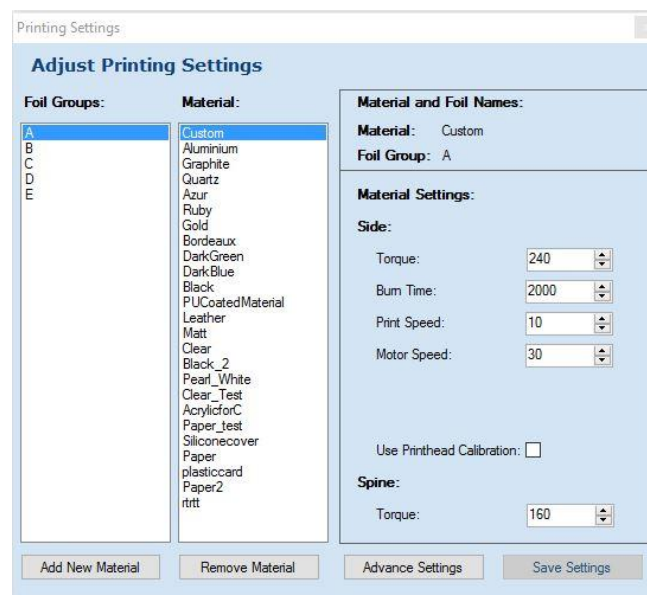

Figure 43: Settings for Printing Parameters

- **Transportation**

This setting is used to move the head to preset position, suitable for transporting the Flat Bed Foil Printer to a different location. This position is also frequently used for servicing the machine. This preset position is the so-called safe location, **with the locking tool must be mount for transportation.**

Transportation:

Figure 44: Setting in Tools for Transportation

- **Smart Temperature Control**

When Smart Temp Control (SMT) is “On”, then automatic temperature adjustment in printhead is used during printing. By default, this setting is off. The setting is not shown if the connected hardware does not support this feature (below version 2.17).

The smart temp control can improve temperature spreading in the printhead making it possible to print large and complex images without burning the foil.

Smart Temp Control:

Figure 45: Settings in Tools for Smart Temperature Control

- **Printhead Calibration**

Printhead calibration when switched on uses the device specific R-value for calculation of desired burntime to be used for better quality printouts. By default, this setting is off. The setting is not shown if the connected hardware does not support this feature (below version 2.35).

Please note that printhead must be calibrated first. Via Testing and Calibration section it is possible to calibrate the printhead.

Printhead Calibration:

Figure 46: Settings in Tools for Printhead Calibration

5.8.2 PELEMAN Products

This option opens the PELEMAN website in the system default browser. The designated website displays useful information about all PELEMAN products. For further information or to place an order, please contact your local distributor.

5.8.3 Check for Updates

Checking the availability of new software and firmware updates from the designated server. It may also be used to update firmware or software by downloading the updates from the server.

The associated printing device must be connected to the system before checking for updates or updating firmware. The system must also be connected to the designated server through Internet / network connection to check and download updates from the server.

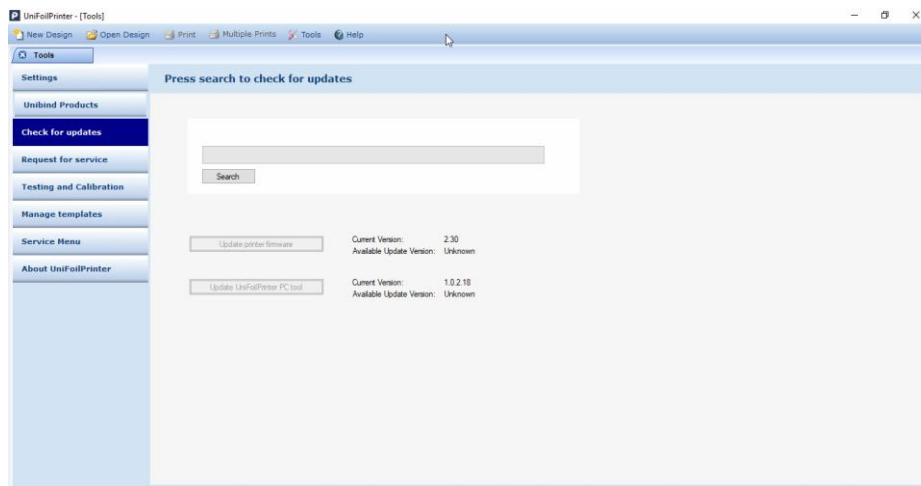

Figure 47: Tools to Check for Updates

If the associated printing device is not connected while checking for updates, then a warning message will prompt the user to connect the printer to the system, as shown in figure 48.

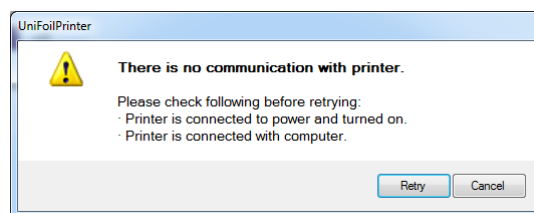

Figure 48: Warning Message if Printer is Not Connected

Similarly, if the system is offline, i.e. not connected to the server, then another warning message will appear asking the user to connect to the server, as shown in figure 49. Please try to check for updates later.

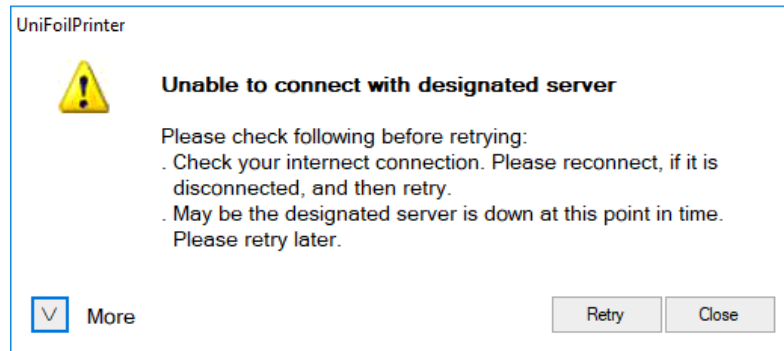

Figure 49: Warning Message if Not Connected to Server

The *Search* button connects the application to the designated server to check the availability of new software and firmware updates. The progress bar displays the completion percentage of the request. The same progress bar is also displayed while updating the firmware / software.

Users may click on *Update printer firmware* to get the updated firmware from the server and install it on the Flat Bed Foil Printer. This button only becomes enabled when a new firmware update is found on the server.

Similarly, users may also click on *Update Flat Bed Foil Printer PC Tool* to update the current version of the Flat Bed Foil Printer software application. This button is only enabled when a new software update is found on the server.



If available, current and new firmware and software versions, will be displayed next to the respective buttons used to update these.

Please note that it is possible to receive error messages of unsuccessful installation of firmware while it is installed correctly in software versions 1.0.0.63 and 1.0.2.0.

5.8.4 Request for Service

Please contact our local representative and provide all necessary information, including **serial number** (can be found on the back) as well as images or a video of the issue. You may also include a picture of the testing page and log files (via help/? button).

5.8.5 Manage Templates

User-created templates may be managed by the user through *Manage Templates* tab in the tools shown in *figure 50*. *User Templates* button can be used to see all user created templates. *All* button must be clicked to see all available template. There are two options to manage user templates: a template can be deleted or edited by clicking on  or  respectively on the corresponding template. These two options are disabled for system templates.

New templates may be created by the user by selecting the *Create New Template* option. Section 5.8.5.1 may be referred to for further information about the creation of new templates. Similarly, the templates may be imported or exported. Section 5.8.5.2 may be referred to for available options regarding importing and exporting templates.

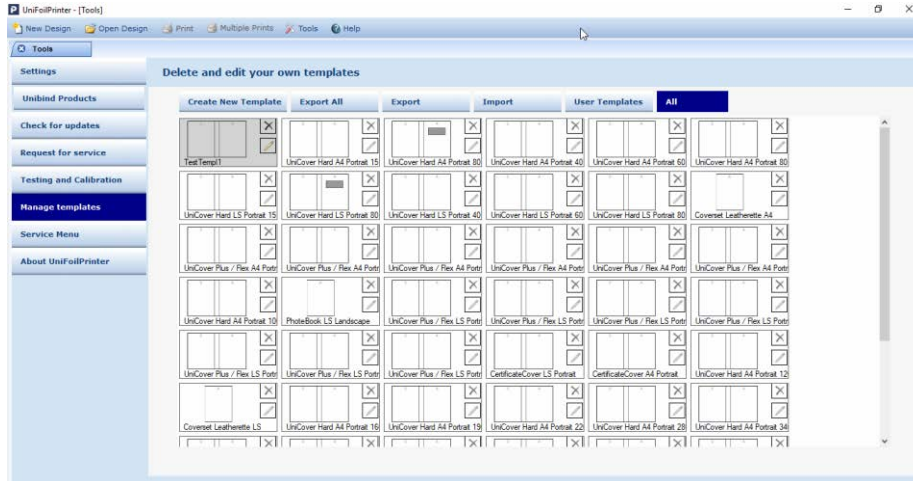

Figure 50: Screen for Managing Templates

5.8.5.1 Create New Template

Users can create new templates based on custom dimensions. Most common PELEMAN products are included in the *Flat Bed Foil Printer PC Tool* by their product names as templates. If a PELEMAN product cannot be found, please check for updates or create a new template. Go to section 5.8.3 to read more about updating the *Flat Bed Foil Printer PC Tool*.

New templates must be based on a printable object. The measurements to be taken are described in this section.

When *Create new template* tab is selected, a warning message will appear, as shown in figure 51, reminding the user of the severity of incorrect values.



Figure 51: Warning Message at Start of Creating New Template

Only click the *Continue* button if you are sure about the values you are about to type in. Failure to do so can cause severe damage to the machine.

The maximum dimensions of the template are 430x304 mm. The actual object, however, can be larger. However, the actual printed area cannot be larger than 440x280 mm.

Select the type of cover for the new template and then click on *Next*.

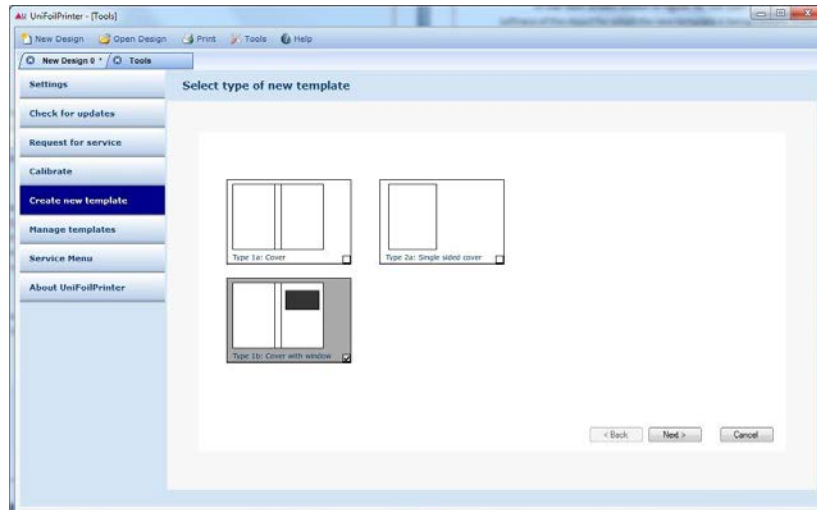

Figure 52: Screen for Selecting Type of New Template

Now, insert dimensions for the new template in appropriate fields shown in figure 53. The values of the dimensions refer to the height, width, thickness etc. of the object to be used with the new template. Dimensions are by default entered in mm or inches according to the selection in settings described in section 5.8.1.

Enter the exact dimensions of the print object. If the entered dimensions are not supported by the Flat Bed Foil Printer, warning messages will appear. If the dimensions are correct, the desired template might not be supported by the Flat Bed Foil Printer, either because the dimensions are too large or too small. Appendix section 10.2 may be referred to for further information regarding supported template dimensions.

If a typing error caused the warning message, the value can be corrected. After inputting all values, click on the *Next* button to continue.

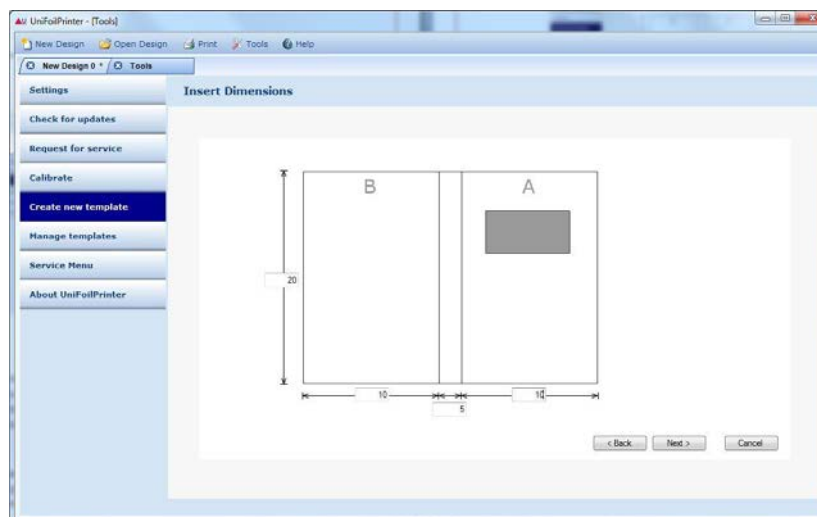

Figure 53: Screen for Inserting Dimensions of New Template

When creating a template type 1b, an additional screen to get measurements related to the window on the cover will appear.

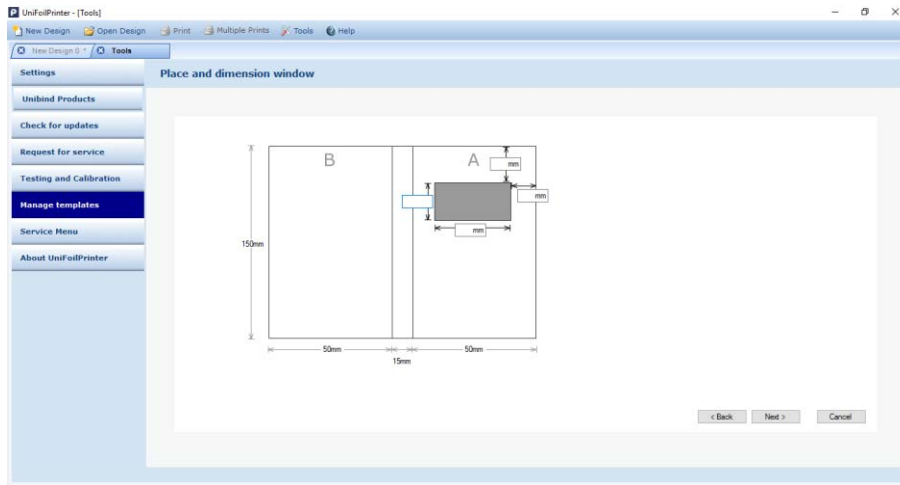

Figure 54: Screen for Inserting Dimensions of Window in New Template

In the next screen shown in *figure 55*, the user will be required to select a unique name for the new template. Please note that the names of Flat Bed Foil Printer existing templates cannot be used for new templates. Click on *Save* button to create a new template.

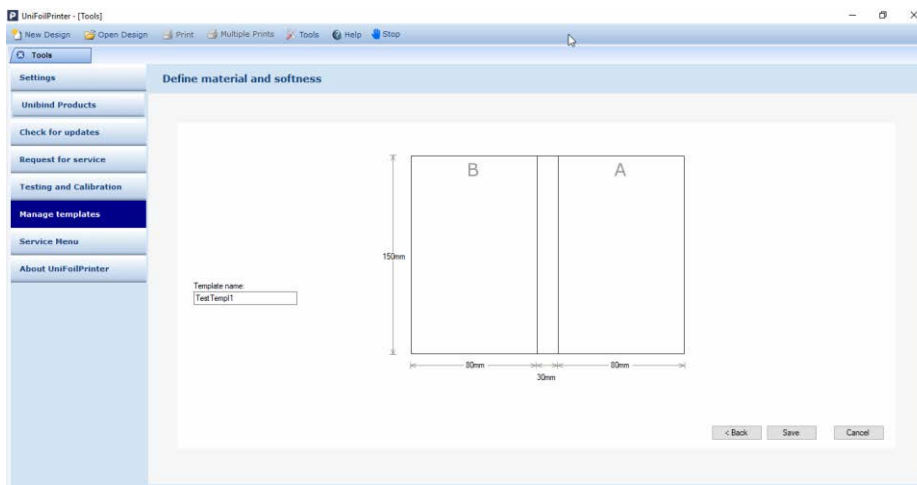

Figure 55: Screen for Selecting Material, Softness and Name of New Template

After the successful creation of a new template, a message will appear asking the user to create a new design based on this newly saved template. The user may then continue.

5.8.5.2 Importing/ Exporting templates

With *Import* / *Export* buttons, it is possible to exchange templates. Use *Export* button to save the selected template as a *.upt* file. Use *Import* to load a template from a *.upt* file. To export all user templates, *Export All* button may be used.

5.8.6 Testing and Calibration

5.8.6.1 Calibrate Printhead

Due to production tolerances, the R-value between different printheads can vary from the “ideal” value of 3000.

The different R-values between printheads result in different print results as the value directly influences the amount of heat generated by the printhead.

Different print results can be avoided by providing the R-value of the specific printhead in the software. The R-value (4 digits) can be found on the printhead as indicated in the picture below.

Once the R-value is provided in the software AND the “printhead calibration” function is activated, the software will adjust the R-value deviation according to the ideal value of 3000 and generate print results that are consistent between different printers.

This function together, with Smart Temp Control, ensure better print result with standard settings.

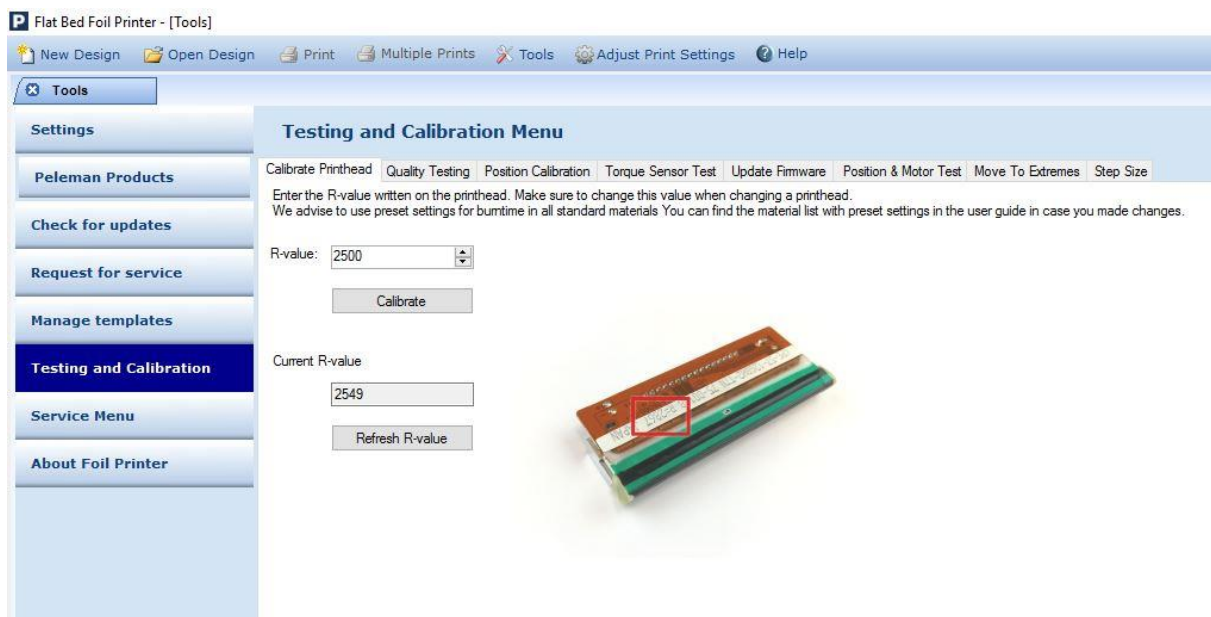

Figure 56: Calibrate Printhead tab

To switch ON: Settings-> Printhead Calibration (ON)

Enter the R-value written on the label of the printhead (field with 2500) and hit ‘Calibrate’, confirm and double check with ‘Refresh R-value’ button.

Make sure to change this value after replacing main board or printhead.

5.8.6.2 Quality testing

In quality testing tab you can find a testing page with different figures and lines. This page will help you in calibration, alignment and quality testing, when needed.

Just make sure the substrate/material is well fastened, select correct foil and material and hit 'Print testing Page' button.

You can use quality testing page design to send to support or show to your technician.

5.8.6.3 Position calibration

Calibration is a process during which the hardware prepares itself and corrects its internal processing errors related to positioning its printer head for accurate printing on covers. Follow the instructions to perform calibration and its associated testing.

The calibration is not used to solve misalignment issues and the position is up to 3 mm accurate (compared to the design on the screen) for machines with serial number below PU063xxxxx.

To perform calibration correctly, first print the circle and measure the distance to the edges with high precision. Software will tell you if calibration is needed or not. If calibration is not needed, please exit the process.

If calibration is needed, hit the 'calibrate' button and follow the instructions displayed on the screen. Make sure you are measuring the upper left corner of the printed dot during the calibration. Measurement must be very precise.

Reprint and measure the circle to make sure calibration is successful. Restart the software and repower the machine before making a final test of the circle. If the circle is shifted after power cycle you may need to update your firmware version and calibrate there.

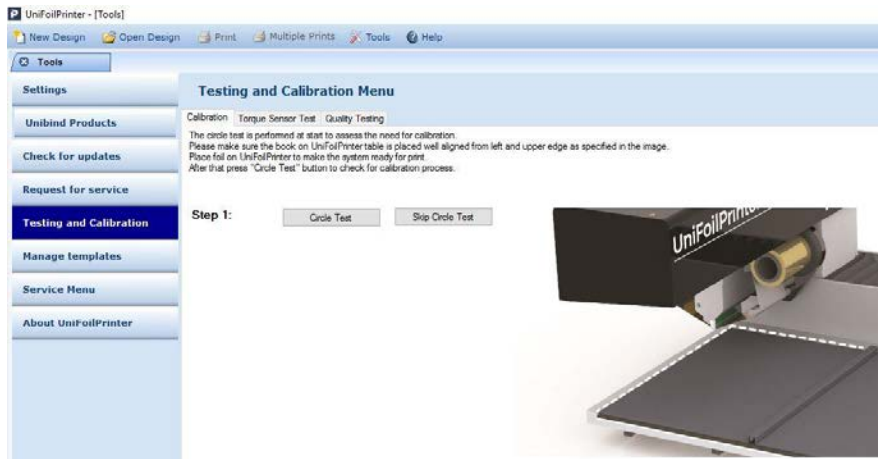

Figure 57: Calibration Start Screen

Please note that it is required to use a basic Peleman cover or sheet of paper with the minimum dimensions of 150x150 mm and place it properly in the corner as shown in the image.

5.8.6.4 Torque sensor test

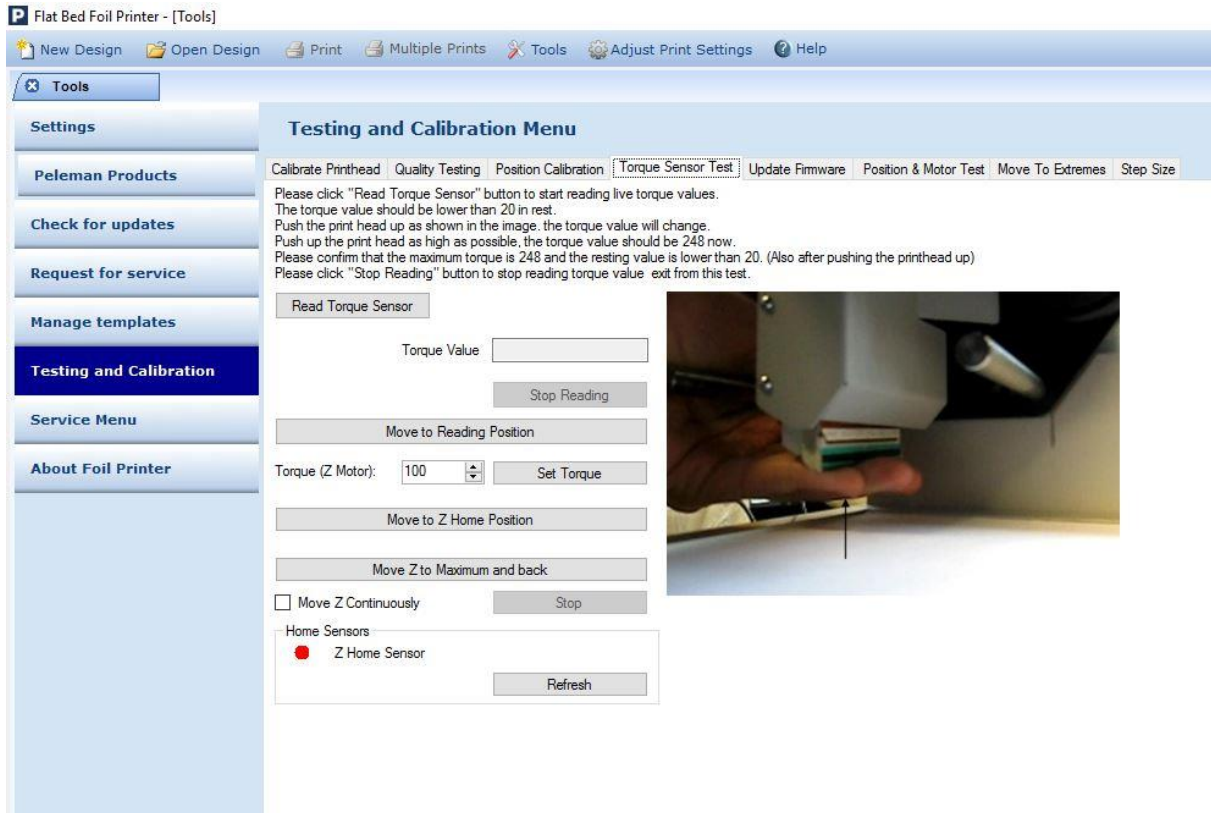

Figure 58: Torque Sensor Test

To test the **pressure** sensor, use the 'Torque Sensor Test' tab. It can be used when the **head error is displayed** on the screen or when you have issues in **downwards movement**.

Follow the instructions on the screen carefully. If the values given in the instructions are different from your software, please proceed to the troubleshooting section or contact our distributor/our official technician. It is not advised to use this functionality without special training and knowledge. However, your distributor or technician may ask you to preform a test before considering a replacement or intervention.

Basic test:

1. Klick on 'read torque sensor' button after the foil is removed.
2. 'Torque Value' Must be below 20. Usually it is around 5. If it is more as 20 – it means that the pressure sensor is reading pressure in rest. It can be due to the stuck mechanism or damaged loadcell. To lose the mechanism push the printhead up manually a few times. If the value does not return to normal it is advised to contact our specialist to grease the mechanism or replace the loadcell.
3. Second test is on maximum pressure value. When pressing the head up manually till the mechanical stop – it must show a value of 248. A bit more is possible but not less as 241. If the value is way below 248 it is advised to double check the firmware

version (for latest version) and/or replace the loadcell. Doublecheck the connector first before contacting our specialist and describe to them your troubleshooting steps.

The 'Move to Reading Position' button and 'Set Torque' functionalities are reserved for further troubleshooting by technicians. They will need a weight scale (capable to at least read 20kg). For a set torque of 240 the weigh is 11-14kg. When it is below 11kg – replacement of the compression spring and/or compression pin can be considered.

5.8.6.5 Update firmware

Firmware update functionality (outside the live server) is reserved for technicians with training. Password will be provided only to them. Therefore, please check for updates via live server first by using 'check for updates' functionality.

5.8.6.6 Position and Motor Test

This functionality is also reserved only for the technicians. You may check the X or Y home position sensors functionality during troubleshooting. Or move the machine to a specific location for motor testing.

The foil motor can be also tested using this tab.

5.8.6.7 Move to extremes

This functionality is used for motor spindles testing. After replacement or grease of the spindles it is advised to run the printer back and forth a few times.

5.8.6.8 Step Size

The step size functionality can be used only by technicians after motor replacement in old printers with serial number lower as PU024xxxxx. In these machines old motors must be replaced for new since it is not more possible to order old motor type. Therefore, step size must be changed manually for this specific motor, usually from 5000 to 3969.

Also, it is possible that after firmware update the step size of old machine will be replaced for new and you'll note distortion in print result (printer will also go slower or faster). In this case you may also need to overwrite the step size with correct value.

Since this functionality can damage the machine if used by unexperienced user – it is password protected and available only to the trained technicians.

5.8.7 Service Menu

The *Service Menu* is used to check the auto status and printer statistics. 'Refresh' button can be used to display the data.

Auto status consists of fields relating to the Flat Bed Foil Printer firmware and is very useful to a technician to check all errors. Please make a screenshot and send it together with your issue description when asking for support.

Printer statistics display the performance and counters related to different hardware activities. Printed length and printing sessions may be a very interesting indicator for maintenance or counting the amount of work that was done for a specific period.

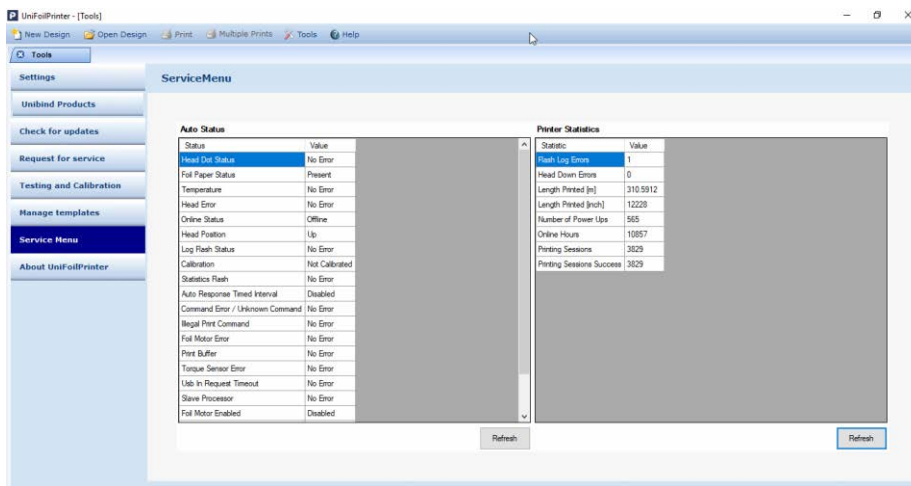

Figure 59: Service Menu in Tools

5.8.8 About the Foil Printer

This option in the tools is used to check the version numbers of the software application as well as firmware. This screen also displays the unique ID of the connected Flat Bed Foil Printer hardware. It is advised to inform us about the s.w. and f.w. versions when contacting for support, reporting bugs or suggesting an improvement.

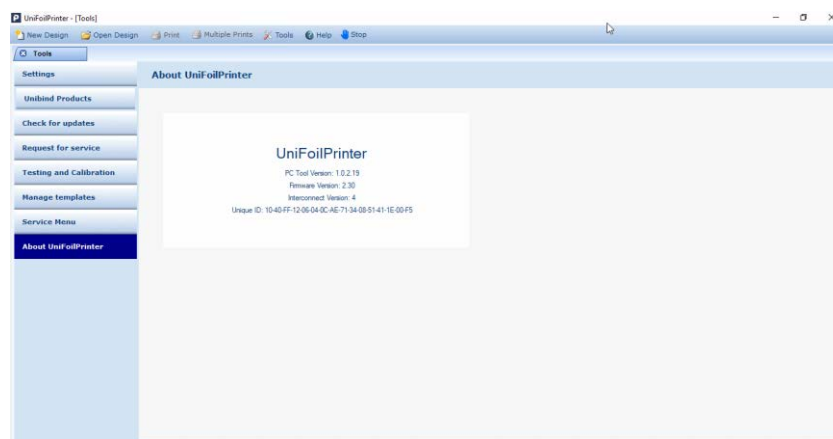

Figure 60: About Flat Bed Foil Printer

5.8.9 Help Button

The help option opens a tab containing help information related to the software.

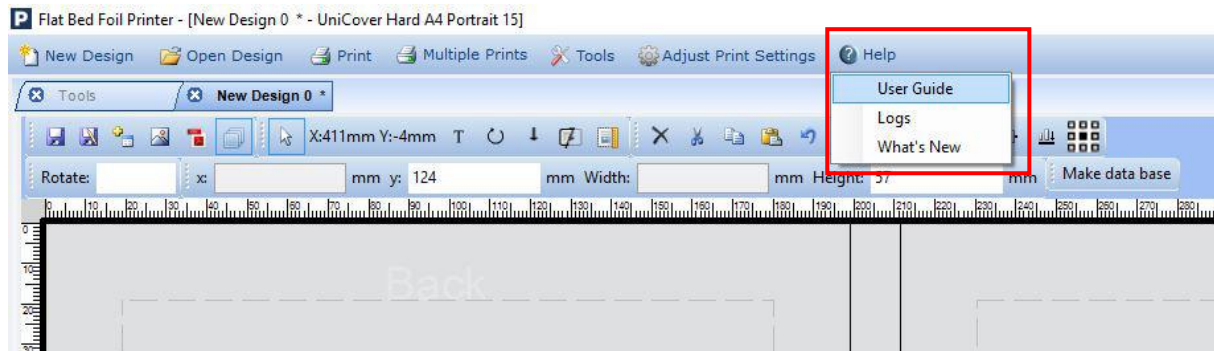

Figure 61: Built-In Software Help

In newer software versions three options are displayed:

- User Guide: by clicking on this option the user guide related to this software version will be displayed. This is the first help manual that you'll need in case of questions. User guide contains basic information about the printer and software. For more information, please contact our distributor in your country.
- Logs: logs are automatically saved software commands between user, software and firmware. You'll need it in case of software bugs so our developers can analyse the issue. Copy and send it in a text document when requesting for service.
- What's New: This option will open the pop-up window about what's new in this version of the software.

5.9 Uninstall

Flat Bed Foil Printer PC Tool can be uninstalled by using one of the below options.

5.9.1 Uninstallation Using Start Menu

To uninstall the software application, go to All Programs in the Start Menu followed by *Flat Bed Foil Printer PC Tool* subfolder and select the option *Uninstall Flat bed Foil Printer PC Tool* as shown in *figure 62*. Follow the instruction on the screen to complete the uninstallation process.

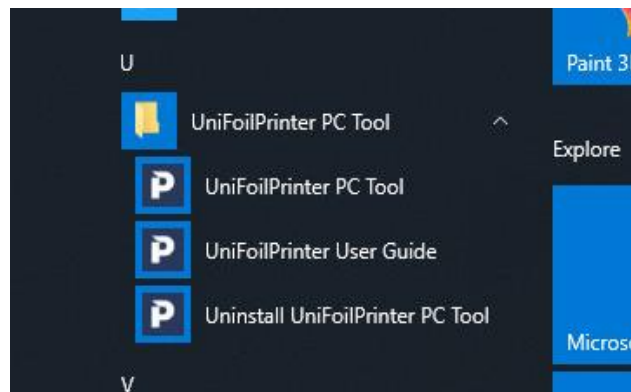

Figure 62: Uninstall Option in Start Menu

5.9.2 Uninstallation Using Control Panel

To uninstall the software application, go to Programs and Features within the control panel to see the list of installed programmes. Select *Flat Bed Foil Printer PC Tool* from the list of installed programs as shown in *figure 63*. Then either select *Uninstall* from the menu options displayed above the list of programs or right click on *Flat Bed Foil Printer PC Tool* & then select *Uninstall* from the menu to uninstall the software application. Follow the instruction on the screen to complete the process.

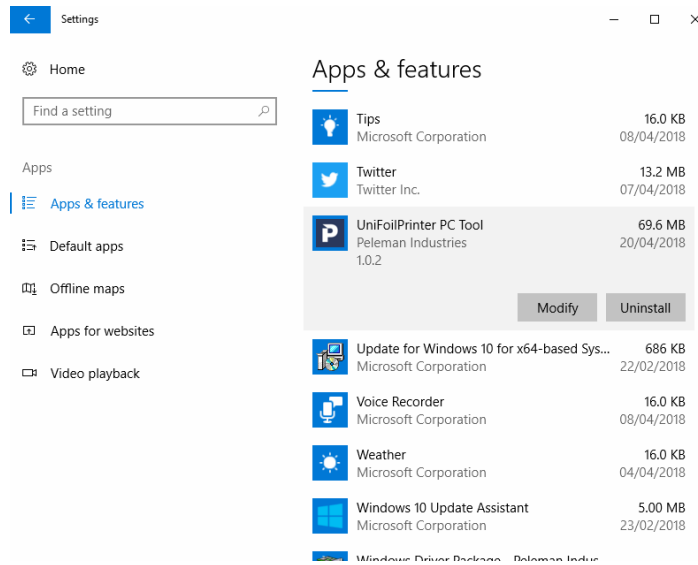

Figure 63: Uninstall Options in Control Panel

5.9.3 Uninstallation Using Installation Setup

Launch setup.exe using the installation source media that was used to install the software. Select *Remove Flat Bed Foil Printer PC Tool* from the given options as shown in figure 64 and then click on *Finish* button. Follow the instruction on the screen to complete the process.

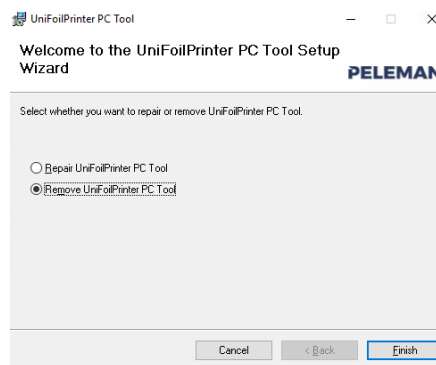

Figure 64: Uninstall Option in Software Installation Setup

6 MAINTENANCE

6.1 Basic maintenance

Every machine needs maintenance to perform at its best over a long period of time, please note the following recommendations and keep an eye on the components discussed below.

To review statistics, please go to *Tools* -> *Service Menu* -> *Refresh the Printer Statistics*. You will then see a window (as shown below). The figures should help you plan for maintenance.

In general, it is advised to inspect the printer after every 10.000 to 25.000 printing sessions, 1-2 times per year.

Printer Statistics	
Statistic	Value
Flash Log Errors	0
Head Down Errors	0
Length Printed [m]	7,42831466666667
Length Printed [inch]	292,453333333333
Number of Power Ups	37
Online Hours	547
Printing Sessions	69
Printing Sessions Success	69
Current R-Value	0

Figure 65: Printer Statistics

6.1.1 Accessories

The condition and presence of accessories must be checked on a weekly basis. At least, a general review should be undertaken after every 10.000 to 25.000 printing sessions. 1-2 times per year.

- We recommend to replace paper rings when they are broken.
- Presence of acrylic plate and foam pad must be confirmed every time. It is advised to replace these (especially the foam pad) at least 2 times a year.
- Presence of cleaning wipes for printhead or isopropyl alcohol. Printhead must be cleaned every week or during every foil change.
- USB cable must be checked and replaced to the 'shielded' type when needed.
- Power supply must be checked (and changed if bad connection is seen) at every check-up.

- f. We recommend to remove old grease from spindles and lubricate these with new grease. Also, excessive lubrication from linear guides can be removed to prevent it from falling on electronics or printing table. Please check this after every 10.000 printing sessions, especially after the first 10.000 sessions.

6.2 Advanced maintenance

6.2.1 Advanced maintenance by technician

Please inspect the following components at every check-up (after every 10.000 to 25.000 printing sessions or at least 1-2 times per year). Maintenance described below must be done by a professional with the required knowledge and experience. Please contact your distributor first.

- a. All cables, connections and sensors should be inspected at every check-up.
- b. Screws, especially on printhead assembly, can be checked/fastened at every check-up. Inspect the paly in components.
- c. Printhead must be inspected for mechanical damage at every check-up. When original foil is used and the printhead is well maintained, it has a lifetime of 25km.
- d. Inspect pressure movement smoothness and loose parts. Inspect the minimum and maximum pressure as well as torque sensor test via testing and calibration menu. Inspect the connector at the loadcell (pressure sensor) and printhead. These must be examined at every check-up.
- e. We advise you to replace the mechanism [SPUP0000134] with a new one or to send this to us/your dealer for revision after every 50.000 printing sessions. Attention! To be done by a professional with professional tools.



Figure 66: SPUP0000134 - Head plate for Z-axis subassembly – GEN 2

- f. After every 100.000 print sessions, we recommend to change motor and spindle in x, y and z [SPUP0000007 + SPUP0000008 + SPUP0000009]. Otherwise, there will be too much play which will cause incorrect print position and 'printer is damaged' error. **Attention! To be done by a professional using professional tools.**

7 TROUBLESHOOTING

7.1 Troubleshooting Bad Print Result



Tip: Scan the QR code to access the demonstrational video

- a. Is the foil installed and spinning correctly? Is the foil tight enough against the head? If not, wind the foil manually until it is tight
- b. Are you using the correct settings? Check selected material. If correctly selected, go to 'Settings' -> 'customize' and check parameters.
- c. Are you using the correct support material?
 - Black foam pad on top for hard covers
 - Polycarbonate sheet on top for soft covers
- d. Clean covers + bars + printhead with isopropyl alcohol or our cleaning wipes (item SPUP0000138)
- e. Try to print with another foil. If another foil colour prints better with same settings on same material contact your local dealer to request a foil change.
- f. Increase the temperature of the medium for a better result. Keep the medium on room temperature. Some materials need to be heated up to achieve a better print result. A heat press can be a solution.
- g. Contact our local representative and include a video of the issue (or a clear problem description) and the serial number of the machine.

7.2 Troubleshooting – Foil Is Not Spinning



Tip: Scan the QR code to access the demonstrational video

- a. The printhead is moving but the printer is not printing. Check the foil holders for broken metal rings. There should be no extra metal rings between the printer and foil coil.
- b. Is the foil installed and spinning correctly? Is the foil tight enough against the printhead? If not, wind the foil manually.

- c. Are you using the correct settings? Check selected material. If correctly selected, go to 'Settings' -> 'customize' and check parameters.
- d. Ensure the surface of the ring is clean and straight. Inspect for splinters and remove if needed.
- e. Add paper ring on right side (item SPUP0000142)
- f. Try to print with another foil. If another foil colour prints better with same settings on same material, contact your local dealer to request a foil change.
- g. Contact our local representative and include a video of the issue (or a clear problem description) and the serial number of the machine.

7.3 Troubleshooting – Calibration

The position calibration is done in the factory and usually there is no need for new position calibration. However, when printer is more as 3mm off the correct position a new calibration may be needed.

Function in 'Testing and Calibration' tab can be used to test calibration.

- a. Perform calibration test. Use build in function in 'testing and calibration' tab to first print a circle and measure the distances. Follow the instructions displayed.
- b. When calibration is passed, please don't perform the calibration.
- c. When calibration is needed (clearly more as 3mm off correct position) you can perform the calibration process. Follow the steps shown in software correctly. Make sure to enter correct coordinates of the dot.
- d. After the process make a circle test again.
- e. Double check the circle test by closing the software and repowering the machine.
- f. If calibration is still fine – the issue is solved.
- g. When printer is again off the correct position repeat the calibration process described above few more times.
- h. When the issue is still there – it is advised to downgrade or update the firmware (examples: 2.32 to 2.28) and calibrate in lower or higher version. Contact your distributor for technical assistance in downgrading.

7.4 Troubleshooting – Errors

7.4.1 No communication with the printer error/printer not connected

- a. Close the software and do a power cycle by disconnecting and re-connecting the power supply
- b. Change USB cable or try other USB port. The USB communication library file known as winusb.dll is required by the *Flat bed Foil Printer PC Tool* application. The subject DLL is usually generated and installed during initial installation of Windows USB driver framework when the associated USB hardware device is connected to the system for the first time. It is usually found in “System32” folder on 32-bit operating systems or in “SysWOW64” folder on 64-bit operating systems. These folders are usually located at the main windows installation folder. For example, if the main windows installation drive is “C:”, then the path for main windows installation folder will be “C:\Windows” on some architectures or “C:\WINNT” on some architectures of the Windows operating system.
- c. Check if any other application is currently connected to the Flat Bed Foil Printer. Only a single instance of any application at a time can be connected with the Flat Bed Foil Printer. Close all other instances of Flat Bed Foil Printer PC Tool application and any other application that might be accessing Flat Bed Foil Printer. Then retry to communicate with Flat Bed Foil Printer through Flat Bed Foil Printer PC Tool application.
- d. Reinstall software. Pay attention for driver installation during the process.
- e. Is the computer connected to power supply with grounding? If not, connect your computer to proper power supply.

7.4.2 Printer is damaged error

- a. Is the lock tool removed?
- b. Inspect the movements of the printer after connecting to power supply. Inspect the sensors and cables.
- c. Contact our local representative and include a video of the issue (or a clear problem description) and the serial number of the machine.

7.4.3 Head error

- a. Remove the foil and press the head upwards manually 5 – 10 times till the end to loosen the mechanism inside.
- b. Check torque via software. Go to 'Tools' -> 'Testing and Calibration' -> 'Read Torque'. Follow instructions. If something is not correct:
 - a. Pressure is >20 in rest position = mechanism is stuck-> step a.
 - b. Pressure is lower than 245 (mechanical stop) -> check connector, replace loadcell and/or contact our representative
- c. Check for play in the pressure mechanism. Are there any parts feeling loose?
- d. Contact our representative for additional technical support.

7.4.4 Dots damaged error

- a. Clean printhead with isopropyl alcohol or our cleaning wipes. Close the application and do a power cycle by disconnecting and re-connecting to power supply. Retry printing.
- b. Inspect printhead for mechanical damage. If there is mechanical damage on printhead, it must be replaced.
- c. Contact our local representative and include a video of the issue (or a clear problem description) and the serial number of the machine.

7.4.5 Driver installation

It is possible that in software versions 1.0.0.63 and 1.0.2.0, the driver installation will be unsuccessful on Windows 8 and 10 operating systems. Therefore, O.S. will not see the connected printer. Check connection in Tools -> About Foil Printer.

To install the driver correctly, follow the steps (step by step instructions on how to install the driver on Windows 10 can be found in download folder of the older software):

Remove the software version, go to PC Settings -> Update & security -> Recovery -> in advanced startup click 'Restart now' -> Troubleshooting -> Advanced options -> Startup settings -> Restart -> F7 (disable driver signature enforcement) -> Install the software and pay attention to driver installation window.

8 SHIPPING AND TRANSPORTATION



Tip: Scan the QR code to access the demonstrational video

When shipping the machine to get it repaired or transporting it to another location, we advise to use the original box and lock the head with head locking tool.

Contact your local distributor for support and shipping information.

1. Go to Settings -> Move to transport (**attention**, the head will start to move!)
2. Remove USB and power cables within 30 seconds.
3. Connect the locking tool firmly with 4 supplied screws
4. Place the machine in the original box or use a custom hard box
5. Optional: add instructions for technician if you are shipping it for repair. Samples with bad print result and explanation can help to identify the issue faster.
6. Make sure the box is fastened firmly with straps or a very strong tape

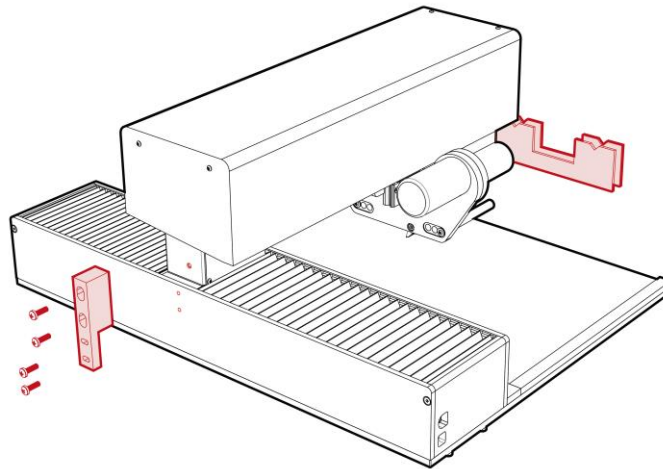

Figure 67: Attach the locking tool and add cardboard supports

9 FREQUENTLY ASKED QUESTIONS (FAQs)

Q1. How to install the associated USB communication drivers for *Flat Bed Foil Printer*?

Ans. Driver will be automatically installed during the software installation process. Please note that for some software versions you will need to switch off the driver signature enforcement (see troubleshooting section).

Q2. How to create a new design in *Flat Bed Foil Printer PC Tool*?

Ans. Section 5.5 of this manual may be referred to for details on creating a new design based on the templates supported by the *Flat Bed Foil Printer PC Tool*.

Q3. What is the lifetime of the printhead?

Ans. The lifetime is about 20km of ribbon. However, the value highly depends on the usage of the printhead. For example, if you always print without ribbon, the lifetime is only 1km.

Q4. How to maintain the Flat Bed Foil Printer?

Ans. It is important to clean the printhead and metal bars with our cleaning wipes (item SPUP0000138) on a regular basis. After a few years, use grease (item SPUP0000122) to lubricate the spindle and check for loose parts. You may also need new underlay foam pad (item SPUP0000046) and new acrylic plate (item SPUP0000130). Contact your distributor to place an order for these items or request a service check-up and repair. Please see chapter 'Maintenance' for more details.

Q5. How can I find settings to print on my material?

Ans. To change settings, go to Tools->Customize and adjust settings for existing material or make a new material. After saving the settings, go back to your design and select that material. By changing burn time, torque and foil type, you will be able to find the perfect settings.

Q6. My printer is damaged, what can I do?

Ans. First, go through the troubleshooting section of this manual. If the given options proved to be unsuccessful, contact your local distributor or representative with the serial number of the printer, clear problem description and pictures or a video of the issue.

10 APPENDICES

10.1 List of Keyboard Shortcuts

Table 4: Keyboard Shortcuts

KEYBOARD SHORTCUTS	DESCRIPTION
Backspace	To delete the character before the cursor in the selected text box
Ctrl + A	To select all text in the currently selected text box, if text editing is active To select all design elements on the currently active layer, when text editing is not active
Ctrl + B	To make the characters bold / unbold in the selected text box
Ctrl + C	To copy the selected text / design element to the clipboard
Ctrl + E	To centre align the selected lines of text in the selected text box
Ctrl + I	To make the characters italic / unitalic in the selected text box
Ctrl + L	To left align the selected lines of text in the selected text box
Ctrl + N	To create a new Flat Bed Foil Printer design
Ctrl + O	To open an existing Flat Bed Foil Printer design
Ctrl + P	To print currently active Flat Bed Foil Printer design
Ctrl + R	To right align the selected lines of text in the selected text box
Ctrl + S	To save currently active Flat Bed Foil Printer design
Ctrl + Shift + P	To open multi-print dialog box for currently active Flat Bed Foil Printer design
Ctrl + T	To open tools
Ctrl + U	To underline / non-underline characters in the selected text box
Ctrl + V	To paste the copied / cut text / design element from the clipboard
Ctrl + X	To cut the selected text / design element to the clipboard
Ctrl + Z	To undo last performed action
Delete	To delete the character after cursor in the selected text box, when text editing is active To delete the selected elements in the active print area, when text editing is not active or the selected element is not in a text box If no element is selected, then delete the selected print area

KEYBOARD SHORTCUTS	DESCRIPTION
Down Arrow (↓)	To move the cursor to the lower line in the selected text box, when text editing is active To move down the selected element / selected print area, when text editing is not active
End	To move the cursor at end of current line in the selected text box
Enter	To add a new line of text in the selected text box
Home	To move the cursor at the start of current line in the selected text box
Left Arrow (←)	To move the cursor left in the selected text box, if text editing is active To move left the selected element / selected print area, if text editing is not active
Minus (-)	To zoom out a single step (Works only if no element in the design area is selected)
Plus (+)	To zoom in a single step (Works only if no element in the design area is selected)
Right Arrow (→)	To move the cursor right in the selected text box, when text editing is active To move right the selected element / selected print area, when text editing is not active
Shift + Down Arrow (↓)	Select text from current cursor location till same location in lower line in the selected text box
Shift + End	Select text from current cursor location till end of line in the selected text box
Shift + Home	Select text from current cursor location till start of line in the selected text box
Shift + Left Arrow (←)	Select character at left of cursor in the selected text box
Shift + Right Arrow (→)	Select character at right of cursor in the selected text box
Shift + Up Arrow (↑)	Select text from current cursor location till same location in upper line in the selected text box
Up Arrow (↑)	To move the cursor on the upper line in the selected text box, when text editing is active To move up the selected element / selected print area, when text editing is not active
Shift + mouse scroll	Zoom IN or OUT
Escape	If text editing is enabled, then select the associated text design element

KEYBOARD SHORTCUTS	DESCRIPTION
	without enabling editing. To deselect currently selected design element and select its parent print area. To deselect currently selected print area, if no design element is selected.

10.2 Supported Template Dimensions

Printer table dimensions: 600 mm x 600 mm.

Good to know:

- Printer table dimensions: 600 mm x 310 mm.
- Maximum printable area: 440 mm x 280 mm.
- It is not possible to print an area larger as 440 x 280mm in single print job.
- Window cannot be wider or larger than the object.
- Window cannot be placed outside the object.

10.2.1 Type 1a and 1b

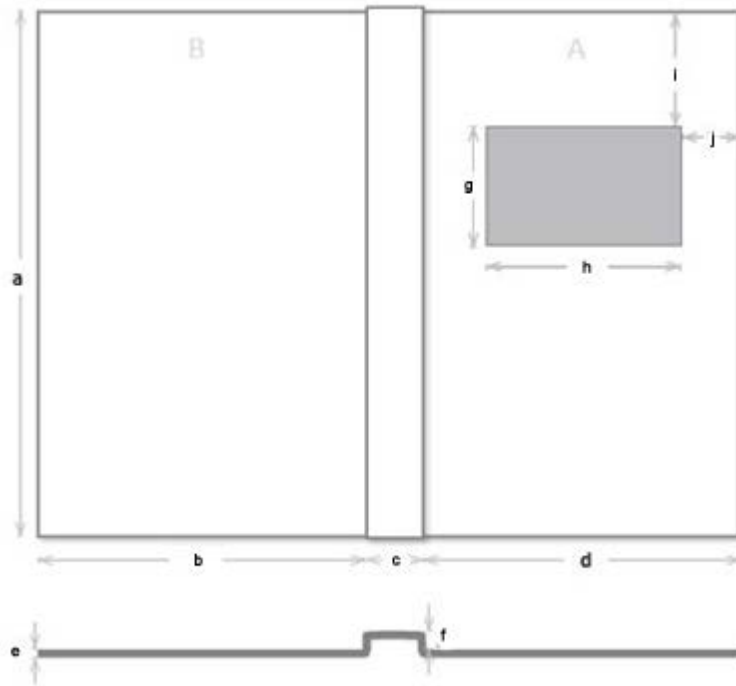

- a: up to 310 mm
- b, d: max. printing length 350 mm
- c: 5 mm – 36 mm
- e: 0.1 mm - max 25 mm
- f: max. 25 mm
- e+f: max. 25 mm

Figure 68: Dimensions of Double Side Cover with Window

- Page height cannot be larger than 350 mm.
- Window cannot be wider or larger than the object.
- Window cannot be placed outside the object.

If any of the following checks applies, error is displayed:

1. $a \leq 8$
2. $a > 304$ and $b + c + d > 430$
3. $b < 5$ and $c < 6$ and $d < 5$
4. $a > 600$
5. $b > 430$ and $d > 430$
6. $c > 430$
7. $a > 304$ and ($b > 304$ or $d > 304$)
8. $g > a$
9. $g \leq 0$
10. $h \leq 0$
11. $h > (b + c + d)$
12. $i \leq 0$
13. $(i + g) > a$
14. $j \leq 0$
15. $(j + h) > (b + c + d)$

10.2.2 Type 2a



- a: up to 480 mm (printed area up to 300mm)
- b: max. length 480 mm (printed area up to 450mm)
- c: 0.1 mm - max 25 mm

Figure 69: Dimensions of Single Side Cover

Page height cannot be larger than 480 mm.

If any of the following checks applies, error is displayed:

1. $a \leq 8$
2. $a > 480$ and $b > 480$
3. $b < 5$
4. $b > 480$
5. $a > 480$ and $b > 480$

10.3 Built-in Printing Settings for Foils and Materials

Table 5: Settings for group A: Gold, Silver, Red and Blue Foils

	Torque	Burn Time	Print Speed	Motor Speed	Spine Torque*
Aluminium	240	1600	10	30	160
Graphite	240	1600	10	30	160
Quartz (Black Metallic)	240	1600	10	30	160
Azur (Blue Metallic)	240	1600	10	30	160
Ruby (Bordeaux Metallic)	225	2100	10	30	160
Gold (Metallic)	240	1600	10	30	160
Bordeaux	235	2200	10	30	160
Dark Green	235	2200	10	30	160
Dark Blue	235	2200	10	30	160
Black	235	2200	10	30	160
PU Coated Material	225	2050	10	30	160
Leather	225	2400	8	25	160
Matt	170	1700	10	30	160
Clear	160	1600	10	30	160

*Use the correct tools for printing on the spine.

Table 6: Settings for group B: Gold, Silver, Red and Blue Foils

	Torque	Burn Time	Print Speed	Motor Speed	Spine Torque*
V-paper 160gr. (uncoated paper)	240	1350	5	20	160

*Use the correct tools for printing on the spine.

Table 7: Settings for group C: Gold and Silver Foils for Offset Sheet

	Torque	Burn Time	Print Speed	Motor Speed	Spine Torque*
Offset Sheet	200	2300	10	30	160

*Use the correct tools for printing on the spine.

Table 8: Settings for group D: Black Foil

	Torque	Burn Time	Speed	Motor Speed	Spine Torque*
Aluminium	225	2400	8	25	160
Graphite	225	2400	8	25	160
Quartz (Black Metallic)	225	2400	8	25	160
Azur (Blue Metallic)	225	2400	8	25	160
Ruby (Bordeaux Metallic)	225	2400	8	25	160
Gold (Metallic)	225	2400	8	25	160
Bordeaux	240	1650	10	30	160
Dark Green	240	1650	10	30	160
Dark Blue	240	1650	10	30	160
Black	240	1650	10	30	160
PU Coated Material	225	2400	8	25	160
Leather	225	2400	8	25	160
Matt	120	2500	10	30	160
Clear	160	1600	10	30	160

*Use the correct tools for printing on the spine.

Table 9: Settings for group E White Foil

	Torque	Burn Time	Speed	Motor Speed	Spine Torque*
Aluminium	235	2500	5	20	160
Graphite	235	2500	5	20	160
Quartz (Black Metallic)	235	2500	5	20	160
Azur (Blue Metallic)	235	2500	5	20	160
Ruby (Bordeaux Metallic)	235	2500	5	20	160
Gold (Metallic)	235	2500	5	20	160
Bordeaux	235	1650	5	20	160
Dark Green	235	1650	5	20	160
Dark Blue	235	1650	5	20	160
Black	235	1650	5	20	160

	Torque	Burn Time	Speed	Motor Speed	Spine Torque*
Leather	235	2400	10	30	160
Matt	235	2400	10	30	160
Clear	160	1900	10	30	160

*Use the correct tools for printing on the spine.

10.4 Custom material grid

This grid contains custom materials that can be used as an **indication** to start printing.

Please note: some materials will move during printing. It is not always possible to combine more print strokes in one image.

Table 10: Custom Material Grid

Material	Foil group	Torque	Burn Time	Print Speed	Motor speed
Extruded Acrylic	A	60-100	1200-1300	8	25
PU Coated materials	A	225	2050	10	30
PU Coated materials	D	225	2400	8	25
Artificial leather	A	180	1750	10	30
*Gift boxes - laminated	A	80-200	2500	10	30
Photo paper	A	50-100	1600-1800	10	30
Glossy cardboard	A	100	1700	10	30
Clear thin film	A	100	1700	10	30
Adhesive clear film	A	100	1600	10	30
Semi matt cardboard	A	100	1600	10	30
Adhesive white vinyl	A	150-200	2200	5	30
Transfer film	A	100	1900	5	30
CM 300 gr. coated paper**	A	225	2400	8	25
Lessebo 300gr uncoated paper (with blank spots)**	B	180	1700	5	20
Arches 88 - 300gr uncoated	B	160	1350	5	20

Material	Foil group	Torque	Burn Time	Print Speed	Motor speed
Extruded Acrylic	A	60-100	1200-1300	8	25
PU Coated materials	A	225	2050	10	30
PU Coated materials	D	225	2400	8	25
Artificial leather	A	180	1750	10	30
*Gift boxes - laminated	A	80-200	2500	10	30
Photo paper	A	50-100	1600-1800	10	30
Glossy cardboard	A	100	1700	10	30
Clear thin film	A	100	1700	10	30
Adhesive clear film	A	100	1600	10	30
Semi matt cardboard	A	100	1600	10	30
Adhesive white vinyl	A	150-200	2200	5	30
Transfer film	A	100	1900	5	30
CM 300 gr. coated paper**	A	225	2400	8	25
Lessebo 300gr uncoated paper (with blank spots)**	B	180	1700	5	20
paper (with blank spots)**					
Arches Watercolor Hot Pressed 300gr paper (with blank spots)**	B	180	1800	5	20
Canson Vivaldi Smooth Surfase White - 240gr (with few blank spots)**	B	180	1800	5	20
Steinbach GO 300gr**	B	180	1800	5	20
Papier Union 300gr Malmero (Black)**	B	160	1200-1350	5	20

**Add 2-4 of same sheets as underlay

Blank spots = unprinted spots due to irregular surface.

10.5 Default Template Specifications

10.5.1 Preset Margins

Preset margins for all default and user templates:

- Margins on all sides of hard covers: 19mm
- Margins on all sides of soft covers: 8mm
- Margins on spine towards both sides of covers: 3mm
- Margins around windows: 5mm

10.5.2 Factory Set

Factory includes the following default templates:

Table 11: Factory template dimensions

S.NO	Name	Softness	Orientation	Height	Back Cover width	Front Cover Width	Spine width
1	UniCover Hard A4 Portrait 15	Hard	Portrait	304	199	199	12.5
2	UniCover Hard A4 Portrait 40	Hard	Portrait	304	199	199	15
3	UniCover Hard A4 Portrait 60	Hard	Portrait	304	199	199	17
4	UniCover Hard A4 Portrait 80	Hard	Portrait	304	199	199	20
5	UniCover Hard A4 Portrait 80 Wrapped window	Hard	Portrait	304	199	199	20
6	UniCover Hard A4 Portrait 100	Hard	Portrait	304	199	199	22
7	UniCover Hard A4 Portrait 120	Hard	Portrait	304	199	199	23
8	UniCover Hard A4 Portrait 160	Hard	Portrait	304	199	199	28
9	UniCover Hard A4 Portrait 190	Hard	Portrait	304	199	199	31
10	UniCover Hard A4 Portrait 220	Hard	Portrait	304	199	199	34
11	UniCover Hard A4 Portrait 280	Hard	Portrait	304	199	199	40
12	UniCover Hard A4 Portrait 340	Hard	Portrait	304	199	199	46
13	UniCover Hard LS Portrait 15	Hard	Portrait	286	205	205	12.5
14	UniCover Hard LS Portrait 40	Hard	Portrait	286	205	205	15

15	UniCover Hard LS Portrait 60	Hard	Portrait	286	205	205	17
16	UniCover Hard LS Portrait 80	Hard	Portrait	286	205	205	20
17	UniCover Hard LS Portrait 80 Wrapped window	Hard	Portrait	286	205	205	20
18	UniCover Hard LS Portrait 100	Hard	Portrait	286	205	205	22
19	UniCover Hard LS Portrait 120	Hard	Portrait	286	205	205	23
20	UniCover Hard LS Portrait 160	Hard	Portrait	286	205	205	28
21	UniCover Hard LS Portrait 190	Hard	Portrait	286	205	205	31
22	UniCover Hard LS Portrait 220	Hard	Portrait	286	205	205	34
23	UniCover Hard LS Portrait 280	Hard	Portrait	286	205	205	40
24	UniCover Hard LS Portrait 340	Hard	Portrait	286	205	205	46
25	PhotoBook A4 Landscape	Hard	Landscape	217	286	-	-
26	PhotoBook LS Landscape	Hard	Landscape	222	268	-	-
27	Certificate Cover A4 Portrait	Hard	Portrait	310	220	220	15
28	Certificate Cover LS Portrait	Hard	Portrait	284	225	225	15
29	Coverset Leatherette A4	Hard	Landscape	297	210	-	-
30	Coverset Leatherette LS	Hard	Landscape	280	216	-	-
31	UniCover Plus / Flex A4 Portrait 15	Soft	Portrait	297	199	199	9
32	UniCover Plus / Flex A4 Portrait 40	Soft	Portrait	297	198	198	14
33	UniCover Plus / Flex A4 Portrait 60	Soft	Portrait	297	198	198	16
34	UniCover Plus / Flex A4 Portrait 80	Soft	Portrait	297	198	198	18
35	UniCover Plus / Flex A4 Portrait 100	Soft	Portrait	297	198	198	20
36	UniCover Plus / Flex A4 Portrait 120	Soft	Portrait	297	198	198	21
37	UniCover Plus / Flex A4 Portrait 160	Soft	Portrait	297	198	198	26
38	UniCover Plus / Flex A4 Portrait 220	Soft	Portrait	297	198	198	33

39	UniCover Plus / Flex A4 Portrait 340	Soft	Portrait	297	198	198	45
40	UniCover Plus / Flex LS Portrait 15	Soft	Portrait	281	204	204	9
41	UniCover Plus / Flex LS Portrait 40	Soft	Portrait	281	204	204	14
42	UniCover Plus / Flex LS Portrait 60	Soft	Portrait	281	204	204	16
43	UniCover Plus / Flex LS Portrait 80	Soft	Portrait	281	204	204	18
44	UniCover Plus / Flex LS Portrait 100	Soft	Portrait	281	204	204	20
45	UniCover Plus / Flex LS Portrait 120	Soft	Portrait	281	204	204	21
46	UniCover Plus / Flex LS Portrait 160	Soft	Portrait	281	204	204	26
47	UniCover Plus / Flex LS Portrait 220	Soft	Portrait	281	204	204	33
48	UniCover Plus / Flex LS Portrait 340	Soft	Portrait	281	204	204	45
49	A3	Hard	Portrait	297	420		
50	A4	Hard	Portrait	210	297		
51	Letter	Hard	Portrait	215.9	279.4		
Maximum Print Area				300	450		

10.6 What's new

10.6.1 Version 1.0.0.63

Basic version working perfectly on most computers with O.S. on Windows 7 and earlier versions. For installation on Windows 8 and 10, you'll need to install the software (driver) with turned off driver signature enforcement.

10.6.2 Version 1.0.2.0

Solved front plate crashing when making small print area on top of the design with tiny margins.

Added fonts preview

This version can give font related errors in non-English windows versions as well as when using custom fonts. True type fonts are supported.

10.6.3 Version 1.1.0.0

Driver signature for windows 10.

Improved text management functionalities. Selecting text or a part of the text can now be done with the Ctrl+A, Shift+Home, Shift+End and Shift+left/right/Up/Down arrow keys. To select whole text for editing double-click on the text in text window.

Updated list of product names (e.g.: UniCover Hard 80)

Improved interface with foil layer window, ensuring the easier creation of multi-colour designs

Possibility of moving objects to a specific location with coordinates

Realistic background for UniBind standard products

Improved PDF import functionality

Improved text import functionality

Copy-paste improvements

More detailed error pop-up windows

Calibration and testing tool with clear "How To Do It" explanations without password authentication

Link to our official website to view and order related products

Smart Temp Control (SMT) for automatic temperature adjustment on the printhead, ensuring better print results on larger or more complex images where the foil might burn or result in matt prints due to changing temperature levels. (This function might not be available for older printers with firmware lower as 2.17)

Resolved bugs and additional functionalities for better usability

10.6.4 Version 1.2.0.0

Attention! This software version is only to be used with new firmware 2.47 or up to use the complete functionality.

Printhead Calibration

New Foil groups & materials

Improved coordination system

Increased maximum print area and template dimensions

Image dimensions for import and in the template

Upgraded alignment functions

PDF import options

Multiple prints supporting .txt file formats

Improved Cursor

Enhanced text boxes

New and improved options in testing and calibration tab

Text rotation fixes

Template size adjustment for A4 hard covers (back and front are 1mm smaller now)

Other small improvements and bug fixes

10.7 Parts and Accessories List

Most frequently requested parts:

SPUP0000138 Flat Bed Foil Printer printhead cleaning wipes

SPUP0000097 Locking Tool

UFPR0000021 Double paper clamp **[NEW]**

SPUP0000028 Screw with cross head (for locking tool)

SPUP0000122 Grease for spindles

SPUP0000130 Acrylic plate for soft materials

SPUP0000046 Foam pad

UFPRELEC015 USB cable

UFPRELEC012 Power supply

SPUP0000142 Paper Ring (specify pieces when ordering, usually per 10pcs)

UFPR0000005 Empty Core 65mm

UFPR0000001 Group A Metal Silver ribbon

UFPR0000002 Group A Metal Gold ribbon

UFPR0000006 Group D Black ribbon

UFPR0000018 Group B Metal Silver ribbon

UFPR00000IG Group B Metal Gold ribbon

UFPR0000003 Group A Metal Blue ribbon

UFPR0000004 Group A Metal Red ribbon

UFPR0000020 Group B Metal Blue ribbon

UFPR0000019 Group B Metal Red ribbon

UFPR0000012 Group C Metal Silver ribbon

UFPR0000013 Group C Metal Gold ribbon

UFPR0000014 Group E White ribbon

UFPRELEC017 Printhead

SPUP0000140 Hexagonal tool set for Flat Bed Foil Printer (for basic repair and check)